

TICO

TICO PRO-SPOTTER OPERATOR'S MANUAL



TICO Manufacturing 1/30/2018

TICO



NOTICE — The information within this publication is current as of the time of publication. Information within this manual is subject to change at publisher's discretion and without notification.

DO NOT REMOVE THIS MANUAL FROM THE TRACTOR. OPERATOR NEEDS TO READ, UNDERSTAND, AND FOLLOW ALL THE WARNINGS IN THIS MANUAL. IF THIS TRACTOR IS SOLD, PASS THIS MANUAL TO THE NEW OWNER.



TICO Manufacturing
 Cypress Ridge Industrial Park
 66 Cypress Ridge Drive
 U.S. Hwy 278 North
 Ridgeland, South Carolina 29936 USA
 1-800-289-8426

TABLE OF CONTENTS

INTRODUCTION (OWNERS INFORMATION) 5



CAUTIONS & WARNINGS — Throughout this manual you will find warnings and cautions as seen on page 6.

SERVICE ASSISTANCE 6

VEHICLE MODIFICATIONS 6

SAFETY CHECKS AND PRECAUTIONS 6

 AXLE-FRONT 7

 AXLE-REAR 7

 BRAKE SYSTEM 7

 CAB 8

 ELECTRICAL 8

 FRAME 8

 FUEL SYSTEM 8

 DRIVE SHAFT 9

 STEERING 9

 SUSPENSION 9

 TRANSMISSION 9

 WHEELS:..... 9

 SAMPLE PRE-OPERATION CHECKLIST 10

 NORTH AMERICAN WARRANTY POLICY 11-13

INTRODUCTION (OPERATION) 14

VEHICLE ENTRY AND EXIT 14

OCCUPANT RESTRAINT SYSTEM 15

 SEAT BELT OPERATION 15

 SUSPENSION TYPE SEATS 15

 SEAT ADJUSTMENT 15

CONTROL AND DISPLAY LOCATION 16, 18, 19, 20, 21, 22, 23

CONTROL AND DISPLAY DESCRIPTION 17, 24, 25, 26

 TURN SIGNAL, HIGH BEAM AND EMERGENCY FLASHER CONTROL 27

 STARTING THE VEHICLE – *The standard ignition switch on the TICO tractor is a key type similar to the kind found on Automobiles. Push button and other types of ignition switches are installed as optional equipment* 27

 PARKING THE VEHICLE 28

TABLE OF CONTENTS (CONTINUED)

AIR BRAKE SYSTEM29-30

PARKING BRAKE31

MANUALLY RELEASING TRACTOR SPRING BRAKES (CAGING)31

TRAILER BRAKES33

ENGINE33-35

TRANSMISSION35

HYDRAULIC FIFTH WHEEL LIFTING SYSTEM36

BASIC TRAILER SPOTTING STEPS37

TOWING THE VEHICLE38-39

AXLES40-41

ELECTRICAL42

RELAYS / BREAKERS / FUSES43

INTRODUCTION (MAINTENANCE)44

LUBRICATION AND FLUIDS44-45

AUTOMATIC TRANSMISSION FLUID45

AXLE LUBRICANT46

COOLANT / ANTI-FREEZE46

FUEL47

ENGINE OIL47

HYDRAULIC SYSTEM FLUID48

MULTI-PURPOSE GREASE48

FILTERS48

TICO TRACTOR PREVENTATIVE MAINTENANCE FORM49

TICO MANUFACTURING PREVENTATIVE MAINTENANCE GUIDELINES50

CAB INTERIOR50

CHECK HVAC SYSTEM50

CAB DOWN – EXTERIOR51

CAB UP51

UNDER VEHICLE52

CHASSIS53

LUBRICATION54

TEST DRIVE55

ON-ROAD CERTIFIED ENGINES55-56

CHASSIS LUBRICATION DIAGRAM57

LUBRICATION CHART58

BOOM AND FIFTH WHEEL LUBRICATION DIAGRAM59

INTRODUCTION (OWNERS INFORMATION)

The intention of this manual is to provide basic information on the proper and safe operation of the TICO Spotter jockey tractor.

The first section, entitled “**To The Operator**” has important information on the use of Warnings, Cautions, and Notes that will be found throughout this publication. This section also contains important safety and service support information.

The second section, entitled “**Operation**”, will cover basic safety and operating information on the tractor itself.

The third section, entitled “**Maintenance**”, will cover basic operator maintenance and lubrication. For more detail information on individual components, reference should be made to that component manufacturer’s publication.

Remember that “**SAFE OPERATION**” of the TICO Spotter depends entirely on the “**OPERATOR**”. There is no substitution for a properly trained and knowledgeable operator. The operator should read and understand the information contain here within prior to attempting operation of this equipment. Study this manual and become familiar with all warnings, cautions, and notes contained herein.

 **NOTICE** — Because of the many different options available on our tractor, some options may not be covered within this manual. Contact your nearest TICO dealer if there are any questions.

 **NOTICE** — The TICO tractor may be referred to as “vehicle” or “the vehicle” throughout this manual. Whenever “Operator” is mentioned throughout this manual it refers to the actual driver of the vehicle.

CAUTIONS & WARNINGS

Throughout this manual you will find warnings and cautions such as pictured below:



DANGER — Indicates a potentially imminently hazardous situation which, if not avoided, will result in death or serious injury.



WARNING — Indicates a potentially hazardous situation which, if not avoided, could result in death or serious injury.



CAUTION — Indicates a potentially hazardous situation which, if not avoided, may result in minor or moderate injury.



CAUTION — Before operation of the vehicle check all blind spots and verify that all personnel are clear of the vehicle.



NOTICE — Throughout this manual you will see notes. Notes will be used to show special procedures or point out important facts. Notes will also designate important information regarding this manual and its use.

SERVICE ASSISTANCE

Please call 1-800-BUY-TICO (800) 289-8426 or your local TICO dealer.

VEHICLE MODIFICATIONS

Do not make modifications to your tractor without written approval from TICO Manufacturing. Your vehicle has been designed and manufactured with safety and reliability in mind. Any modifications by the operator or owner could decrease the safety and reliability of your vehicle. Any unauthorized vehicle modifications may also void the TICO Manufacturing Limited Warranty. Do not risk personal safety or vehicle reliability by making unauthorized modifications to your TICO tractor. Contact TICO concerning any proposed modifications to this vehicle.

SAFETY CHECKS AND PRECAUTIONS

All spotting applications are demanding on the vehicle. Maintenance is critical for the continued **SAFE** performance of your tractor. Before operating your TICO it is extremely important that the vehicle is in proper and safe working condition.

The following section is intended to provide a basic knowledge of important safety check procedures and what to look for. These checks must be performed regularly to ensure safe vehicle operation. The frequency of these checks depends on the application of the vehicle.

In general, the best time to make the following safety checks would be during normal maintenance and during daily Pre-Operation Safety Inspections.

TICO Manufacturing highly recommends that all operators complete a **Pre-Operation Safety Inspection** before climbing into the driver's seat. This "Walk Around" is a good way to prevent potential problems. A sample "Pre-Operation Safety Checklist" is provided on page 10. Use this as a guide to come up with an appropriate checklist for your individual vehicle.

During each scheduled maintenance interval or at least once a month, a qualified mechanic should inspect all of the following areas:



NOTICE — If the vehicle is used in a severe application, such as a rail yard operation or in 24 hour operations, a more frequent schedule may be required.

AXLE-FRONT

Maintaining correct front axle alignment is critical and should be performed by a qualified mechanic.

Check to ensure that the axle mounting bolts are securely tightened. Regularly check the front axle for damage, binding or worn parts, and adequate lubrication. Pay special attention to the axle stops. Do not operate the vehicle without the proper axle stops in place.

AXLE-REAR

Check to ensure that the axle mounting bolts are securely tightened. Regularly check the rear axle for damage and oil leaks. Unusual noises and signs of extreme heat may indicate axle damage.

BRAKE SYSTEM

Check the following:

1. Check brake controls for proper operation. Make sure the foot operated treadle in the cab is operating smoothly and is not damaged.
2. Visually inspect the brake drums, brake chambers, and slack adjusters. Check for loose, missing or broken components. Check brake chambers and slack adjusters for cracks and other signs of severe wear.
3. Listen for air leaks in the cab and underneath the chassis. Check air pressure regularly using the dash mounted gauge. Be alert for any sudden drop in pressure while operating the vehicle and after the engine is shut off. A minimum air pressure of 90 PSI is required to operate this vehicle.
4. Visually check hoses and pneumatic lines for damage and chaffing.
5. Check the operation of both the service and parking brake systems. Be alert for any reduction in braking performance or unusual noises while braking.

CAB

Defroster – Operate the defroster to make sure sufficient air is being directed against the windshield. Make sure the blower is operating before the weather requires the defroster.

Doors – Check for positive closing.

Walkways/Steps – Check to ensure that all factory installed walkways, platforms and steps are installed on vehicle securely and are not damaged or loose.

Handholds/Grab Handles – Check to ensure all handholds are installed and are not loose or damaged.

Glass – Check for cracked, broken, scratched or dirty glass.

Cleaning instructions for optional plastic glazing – Wash window with a clean sponge or soft cloth using lukewarm water and mild detergent. Rinse with clean water. Do not use abrasive highly alkaline cleaners. Never scrape with squeegees, razor blades, or other sharp instruments. Remove ice and frost with the cab heater/defroster or by applying heat.

Mirrors – Check to be certain all mirrors are installed and that they are clean.

Seat Belts – Check entire seat belt system for wear and proper operation. Make sure anchor mountings are tight.

Cab Floor – Keep floor clean and clear of trash which may interfere with cab controls.

ELECTRICAL

Horn – Operate steering wheel mounted horn to check operation. (Check optional air horns if equipped).

Instruments – Check operation of all instruments and gauges.

Lights – Check to make sure all lights (interior, exterior, headlights, etc.) function properly. Make sure gauge and dash back lighting is working properly.

Wiring – Check to ensure all wiring is properly secured and protected. Replace worn, cracked or chaffed wires and looms. Make sure factory wiring has not been compromised by improper splicing or modifications.

FRAME

Check for cracks and signs of damage. Pay close attention to highly stressed areas of the frame such as the boom pivot area. Contact your dealer for instructions on frame repair. Do not weld on frame rails unless directed to do so by TICO or by the factory.

DRIVE SHAFT

Check universal joints for wear. If propeller shaft vibrations occur, stop the vehicle immediately to prevent serious damage to the vehicle drive train.

STEERING

Be alert to any change or feel in steering while driving the vehicle. This change or feel may include a change in steering effort, unusual sounds when turning, excessive wheel play or pulling to either side.

If a problem is suspected or felt, check steering components for loose, damaged or worn parts. All steering components such as the pitman arm, tie rods, and drag link must be tight.

Check power steering system for leaks and hose chaffing. Repair any problems before operating the vehicle. Regularly inspect all steering linkages.

SUSPENSION

Check condition of front and optional rear (if installed) suspension components such as mounting brackets and bushings. Check for worn and damaged parts.

Check and maintain the specified torque on all mounting bolts and nuts. Check springs and replace broken or distorted springs.

TRANSMISSION

Follow transmission manufacturer's guidelines for proper maintenance.

WHEELS

Check condition and maintain specified torque on all wheel mounting nuts. Replace missing or broken studs and nuts. Check tire inflation and wear. Do not operate this vehicle with badly worn or damaged tires.



WARNING — If any of the above listed items are evident you need to have the vehicle repaired by a qualified steering technician.



NOTICE — Because of the many options available on TICO tractors it is critical that the owner be aware of all options that may affect the safe operation of the vehicle and take appropriate measures to maintain his/her specific vehicle. Always contact your TICO dealer if any questions arise regarding safe operation of this vehicle.

SAMPLE DAILY PRE-OPERATION CHECKLIST

DAILY PRE-OPERATION CHECKLIST**(Walk Around Inspection)**

- _____ Check tires for damage and proper inflation
- _____ Check cab hold down latch, (air suspension unit), for proper latching
- _____ Check all fluid levels: engine oil, hydraulic, coolant and diesel exhaust fluid
- _____ Drain any moisture from air tanks
- _____ Check cab and frame for any structural damage or cracks
- _____ Check 5th Wheel grease
- _____ Ensure that all steps, walkways and handholds are installed and in good working order
- _____ Inspect trailer electrical cable and trailer air lines for damage.
Make sure both air lines are installed
- _____ Clean all windows if needed
- _____ Check all rear view mirrors; adjust and clean if needed
- _____ Start engine and check transmission fluid level with parking brake applied and transmission shift selector in "neutral"
- _____ Check windshield wiper for proper operation
- _____ Check steering system for any binding. Make sure steering effort is smooth and tight
- _____ Check transmission shift lever for any binding
- _____ Check all lights for proper operation: headlights, turn signals, brake lights, hazard lights, and marker lights
- _____ Check horn(s) for proper operation
- _____ Check boom control lever for proper operation
- _____ Check and fill fuel tank
- _____ Check accelerator for proper operation; should operate smoothly and without any binding

NORTH AMERICAN WARRANTY POLICY**TICO Spotter Tractor North American Warranty Policy**

TERMINAL INVESTMENT CORPORATION (hereinafter referred to as "TICO") warrants to the original owner that each new TICO Pro-Spotter Terminal Tractor will be free from defects in material and workmanship under normal use and service for a period not to exceed 2 years or 6000 hours, whichever occurs first, from commencement of service. For 2 years or 6000 hours both parts and labor will be warranted. TICO has developed a comprehensive warranty policy and warranty system. Our goal is to establish policies that will enable consistent, prompt and equitable processing of warranty requests.

The TICO warranty policy and system will enable our distributors to "know where they stand" in most warranty repair situations. This will enable the distributor to classify whether or not a service repair really is warrantable. The distributor can then deal with the customer more effectively. We at TICO want to make justified warranty claim a prompt, consistent and equitable experience for our mutual customers. It is vital that the warranty registration be completed via registration online and PDI completed and returned to TICO immediately following delivery of vehicle to the customer. This triggers the warranty in our system, enabling the claim to be processed. Completion of the warranty registration is also required by the National Highway Transportation Safety Administration for DOT compliant vehicles in the event contact with user is required. Please consider each claim on its own merits, remembering that this is directly proportionate to your future ability to provide a quality product at a reasonable price. We recommend that all people who deal with warranty service and administration become familiar with the procedures contained in this manual. TICO reserves the right to, at any time, change or revise the provisions of its warranty procedures, effective on or after notification of authorized distributors. All provisions of this manual are effective immediately.

PLEASE MAKE SURE THAT YOUR WARRANTY REGISTRATION AND PDI IS COMPLETED AND RETURNED TO TICO.

INTRODUCTION**I. DETERMINATION OF WARRANTABLE SERVICE**

The question as to whether a repair or replacement is actually a warrantable adjustment is documented in this section to help you make that decision. All warranty claims must be filed within the warranty period of twenty-four (24) months or 6,000 hours and within thirty (30) days of the repair. The claim will not be honored if it does not meet this criteria.

II. DETERMINING WARRANTY RESPONSIBILITY

- A. Has this complaint originated during the stated warranty period?
- B. Is the malfunction a result of abuse or misuses?
- C. Has the unit been maintained properly?
- D. If the complaint has originated during the warranty period, there is no evidence of abuse or misuse and the unit has had proper maintenance, the distributor should proceed to file a warranty claim. This does not, however, ensure that the claim be approved.
- E. Is warranty registration on file?

TICO Pro-Spotter Tractor North American Warranty Policy continued:

DETERMINATION OF WARRANTY

What is Covered by This Warranty. TICO warrants, to the original purchaser only, that the truck that is the subject of this sale is free from defects in material and workmanship. The duration of this warranty is as follows:

- a. Frames – As to the main structural frame, seven years from the date of delivery.
- d. TICO Cab – As to the driver's structural cabin compartment, five years from the date of delivery.
- f. As to all other parts and components, one year from date of delivery or 3,000 hours of use, whichever comes first.

If the purchaser discovers within the applicable period a defect in material or workmanship, it must promptly notify TICO in writing. In any event such notification shall be received by TICO, in the case a defect in the mainframe, no later than 73 months from date of delivery, and in the case of a defect in any other part or component, no later than 25 months from the date of delivery or one month after the first 6,000 hours, whichever comes first. Within a reasonable time after such notification, TICO will correct any defect in material or workmanship with either new or used replacement parts, at TICO's option.

TICO will pay for the costs of correcting defects as follows:

- a. For defects in material or workmanship during the first twenty-four months from the date of delivery or the first 6,000 hours, whichever comes first, both parts and labor are at TICO's expense. All warranty work is subject to TICO's prior examination and approval and will be performed by TICO or at service centers designated by TICO. All transportation to and from designated service center will be at the purchaser's expense and is not included as a cost of repair covered by this warranty. These remedies are the purchaser's exclusive remedies for breach of warranty.

STANDARD WARRANTY POLICY

What is Not Covered by This Warranty.

TICO does not warrant engines, transmissions, tires, batteries or any other component which has a warranty covered by its manufacturer. In addition, TICO does not warrant (a) damage caused by use of the truck for purposes other than those for which it was designed; (b) damage caused by accident or the negligence of the purchaser or any third party or by disasters such as fire, flood, wind and lightning; (c) damage caused by the purchaser's failure to provide normal maintenance as customarily accepted in the industry or as set forth in the maintenance guidelines; (d) filters, belts, brake linings, lights, breakers, and lubricants which are part of normal maintenance service requirements; (e) damage caused by unauthorized or improper installation of attachments, repairs, modifications or alterations; (f) damage caused by replacement of original parts or components with unauthorized substitutes; (g) damage during shipment, or (h) any other abuse or misuse by purchaser.

Disclaimer of Warranty. THE FOREGOING WARRANTIES ARE IN LIEU OF ALL OTHER WARRANTIES, EXPRESS OR IMPLIED, INCLUDING BUT NOT LIMITED TO THE IMPLIED WARRANTIES OF MERCHANTABILITY AND FITNESS FOR A PARTICULAR PURPOSE.

Limitation of Remedies. In no case shall TICO be liable for any special, incidental, or consequential damages based upon breach of warranty, breach of contract, negligence, strict tort, or any other legal theory. Such damages include, but are not limited to, loss of profits, loss of savings or revenue, loss of use of the truck or any associated equipment, cost of capital, cost of any substitute truck, equipment, facilities, or services, downtime, the claims or third parties including customers, and injury to property. This limitation does not apply to claims for personal injury. Some states do not allow limit on warranties, or on remedies for breach in certain transactions. In such states, the limits in this paragraph and in paragraph (3) may not apply.

TICO Pro-Spotter Tractor North American Warranty Policy continued:

Warranty Claim Procedures. The purchaser must notify TICO of a warranty claim prior to any warranty work. TICO will provide the purchaser with further instructions on how to proceed with such warranty claim. Notice of a warranty claim and all other warranty correspondence must be sent digitally to Warranty@ticotracors.com or physically to: TICO, 66 Cypress Ridge Dr, Ridgeland, SC 29936. TICO may designate new or additional addresses.

Time Limit for Bringing Suit. Any action for breach of warranty as to the mainframe must be commenced within 75 months following delivery of the truck. Any action for breach of warranty as to any other part or component must be commenced within 27 months following delivery of the truck or within the first three months following the first 6000 hours of use, whichever comes first.

No Other Warranties. Unless modified in writing signed by both parties, this agreement is understood to be the complete, and exclusive agreement between the parties, superseding all prior agreements, oral or written, and all other communications between the parties (including without limitation any terms and conditions contained in any purchase order or sales invoice issued pursuant to the sale of this truck) relating to the subject matter of this agreement. No employee of TICO or any other party is authorized to make any warranty in addition to those made in this agreement.

Warranty Registration. This warranty is conditioned upon receipt by TICO of a completed warranty registration following delivery of vehicle to the customer. The customer registration must be on file for any warranty claim to be considered. If no Warranty registration is filed the warranty of the tractor is initiated at the ship date. *Note: Contact specific product OEM: Cummins, Dana, Meritor, Allison.

MAJOR COMPONENTS WARRANTY

* For additional warranty information, please contact the major components manufacturer or visit their websites.

1. **Disclaimer of Warranty.** THE FOREGOING WARRANTIES ARE IN LIEU OF ALL OTHER WARRANTIES, EXPRESS OR IMPLIED, INCLUDING BUT NOT LIMITED TO THE IMPLIED WARRANTIES OF MERCHANTABILITY AND FITNESS FOR A PARTICULAR PURPOSE.
2. **Limitation of Remedies.** In no case shall TICO be liable for any special, incidental or consequential damages based upon breach of warranty, breach of contract, Negligence, strict tort, or any other legal theory. Such damages include, but are not limited to, loss of profits, loss of savings or revenue, loss of use of the coach body or any associated equipment, cost of capital, cost of any substitute coach body, equipment, facilities or services, downtime, the claims of third parties including customers, and injury to property. This limitation does not apply to claims for personal injury. Some states do not allow limits on warranties, or on remedies for breach in certain transactions. In such states, the limits in this paragraph and in paragraph (3) may not apply.
3. **Time Limit for Bring Suit.** Any action for breach of warranty must be commenced within three months following the expiration of the warranty period.
4. **No Other Warranties.** Unless modified in a writing signed by both parties, this agreement is understood to be the complete and exclusive agreement between the parties, superseding all prior agreements, oral or written, and all other communications between the parties (including without limitation any terms and conditions contained in any purchase order or sales invoice issued pursuant to the sale of this truck) relating to the subject matter of this agreement. No employee of TICO or any other party is authorized to make any warranty in addition to those made in this agreement.

INTRODUCTION (OPERATION)

The following section on OPERATION should be read carefully. It covers important information that every operator must know before operating any TICO tractor.

This manual is intended to cover the standard TICO tractor and some of the most common options. Not all of the customer ordered optional equipment or systems will be covered in this manual. If the operation of any component or system on your vehicle is not covered in this manual, call your TICO dealer for assistance.



CAUTION — TICO manufacturing highly recommends that all individuals that operate this vehicle have sufficient training to operate this type of vehicle. Although most TICO tractors are not sold as highway legal vehicles, this does not mean they are intended to be operated by untrained personnel. This manual is not intended to be a training guide for Yard Tractor operators. It is the operator's responsibility to obtain sufficient training in order to operate this vehicle safely. **DO NOT ATTEMPT TO OPERATE THIS VEHICLE WITHOUT ADEQUATE TRAINING.**

VEHICLE ENTRY AND EXIT

The TICO tractor is designed for easy entry and exit. The walkways, steps, and handholds are designed with operator safety in mind. As with any vehicle of this type, care must be taken when climbing in or out of your TICO tractor. Remember, be careful!

1. Entry and exit should be made slowly and carefully.
2. A three-point stance should be used. Three out of the four extremities (hands and feet) should be in contact with the vehicle at all times.
3. Face inward toward steps when entering and exiting.
4. Keep steps, walkways and handholds in good condition.
5. Keep steps, handholds, walkways and shoes free of grease, mud, dirt, fuel, ice and snow.
6. Use extra care during bad weather, especially when steps and handholds may be icy or wet.



CAUTION — Never remove factory installed walkways, steps or handholds. Do not operate your TICO unless all factory installed steps, walkways and handholds are installed and in good working condition.



CAUTION — Failure to exercise caution when entering and exiting this vehicle can result in personal injury.

OCCUPANT RESTRAINT SYSTEM

THE TICO TRACTOR IS EQUIPPED WITH SEAT BELTS. THEY SHOULD BE USED WHENEVER THE VEHICLE IS IN OPERATION.

SEAT BELT OPERATION

The seat belt system used on TICO tractors is a 3 point shoulder harness restraint with an automatic retractor. Before fastening the seat belt, be sure to adjust the seat to a comfortable driving position. To fasten the belt, pull the belt low across your shoulder and insert the tongue into the buckle. To release the seat belt, press the button on the buckle and the belt will retract automatically.

SUSPENSION TYPE SEATS

All TICO tractors have a suspension type seat as standard equipment.



CAUTION — Due to the vertical travel of suspension seats, the operator must insure that there is adequate head clearance when the seat is at the top of its upward travel.

SEAT ADJUSTMENT

Refer to the seat manufacturer for additional information or to the instruction decal located on the seat base. Your local TICO dealer can assist with any questions.

Adjust the seat to the comfortable position for the operator to have full control of all cab controls and displays. This position is obtained by changing the air pressure in the suspension, which changes the height. The fore and aft position is obtained by moving the seat cushion and back on its slides. Once this position is achieved, tighten the seat belt tether securely on both sides. The tether will restrain the seat from rising above this position. Now, the seat air suspension may be adjusted to operator's desired firmness.



WARNING — The TICO tractor is designed and equipped to carry only the driver (unless equipped with a trainer's seat). Never allow anyone to ride anywhere inside or outside of the cab. Carrying a passenger is extremely dangerous and can result in serious injury or death. **NEVER CARRY PASSENGERS WITH YOUR TICO.**

CONTROL AND DISPLAY LOCATION

DASH CONTROLS - 2017 CAB

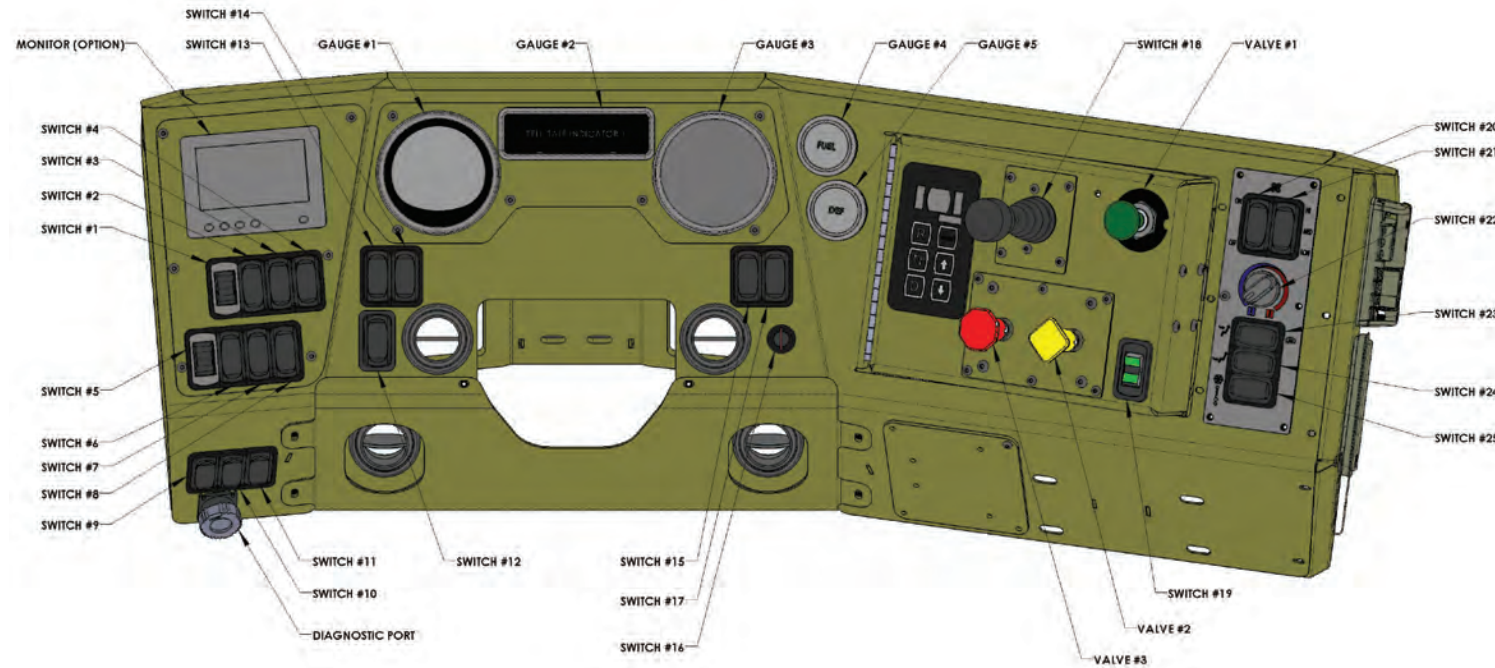

CONTROL AND DISPLAY DESCRIPTION

DASH CONTROLS - 2017 CAB

SWITCHES

- #1: L.H. WORK LIGHTS
- #2: REVERSE LIGHTS
- #3: R.H. WORK LIGHTS
- #4: OPTION
- #5: MIRROR HEAT (OPTION)
- #6: OPTION
- #7: L.H. MIRROR (OPTION)
- #8: R.H. MIRROR (OPTION)
- #9: ABS (OPTION)
- #10: INCREMENT/DECREMENT
- #11: ENGINE DIAGNOSTIC
- #12: RHEOSTAT
- #13: OPTION
- #14: OPTION
- #15: WIPER/WASHER, INTERMITTENT
- #16: IGNITION
- #17: HEADLIGHTS
- #18: BOOM RAISE/LOWER
- #19: DOOR OPEN/CLOSE
- #20: FAN (ON/OFF)
- #21: FAN (HI/MED/LOW)
- #22: TEMPERATURE CONTROL
- #23: UPPER VENT OR DEFROST
- #24: LOWER VENT
- #25: A/C (ON/OFF)

GAUGES

- #1: SPEEDOMETER/ODOMETER
- #2: INDICATORS
- #3: GAGE CLUSTER
- #4: FUEL GAGE
- #5: DEF GAGE

VALVES

- #1: 5TH WHEEL LATCH
- #2: TRACTOR BRAKE
- #3: TRAILER BRAKE

CONTROL AND DISPLAY LOCATION
DASH PANEL – 2011 MODELS

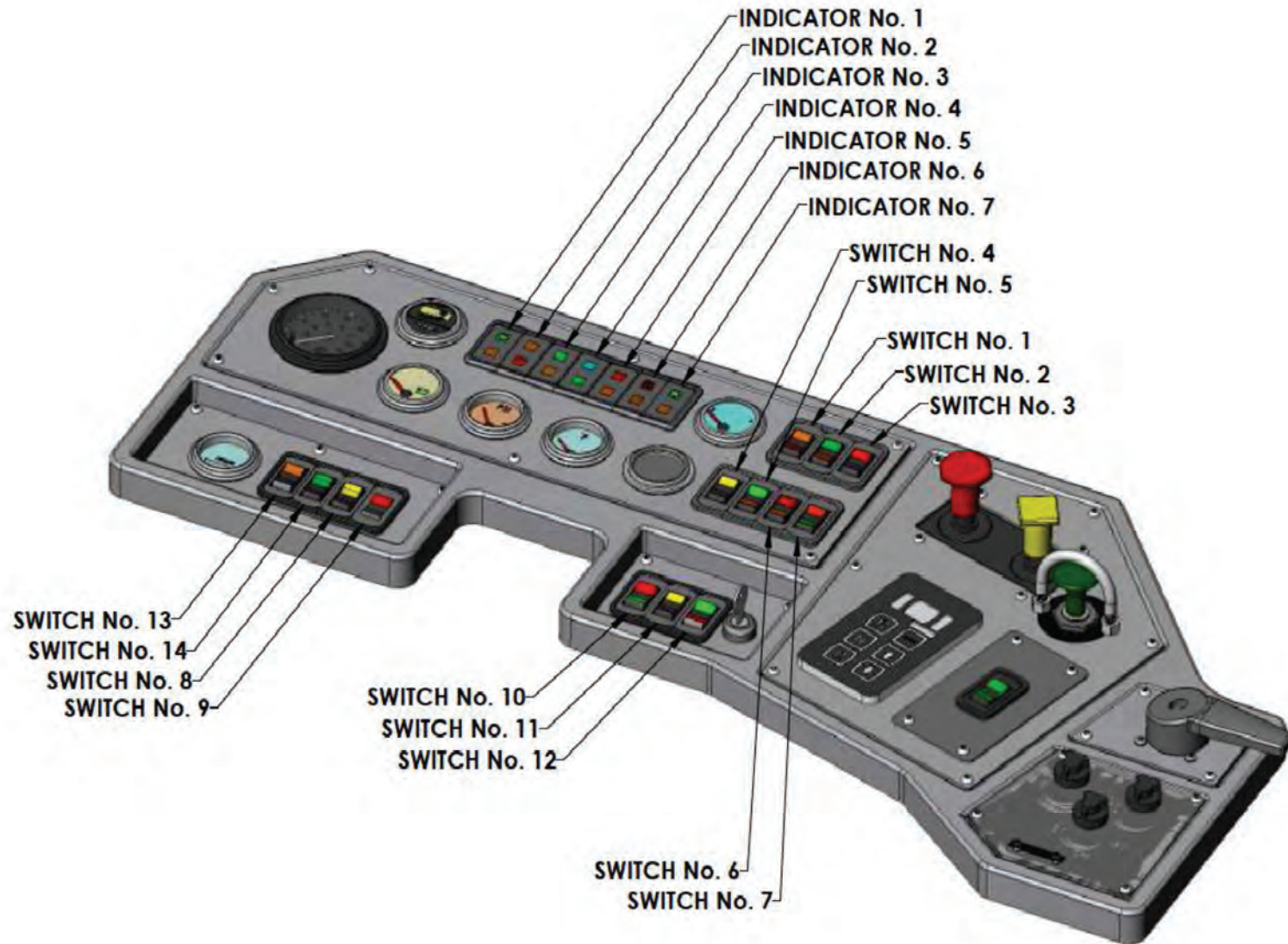

GAUGE PANEL

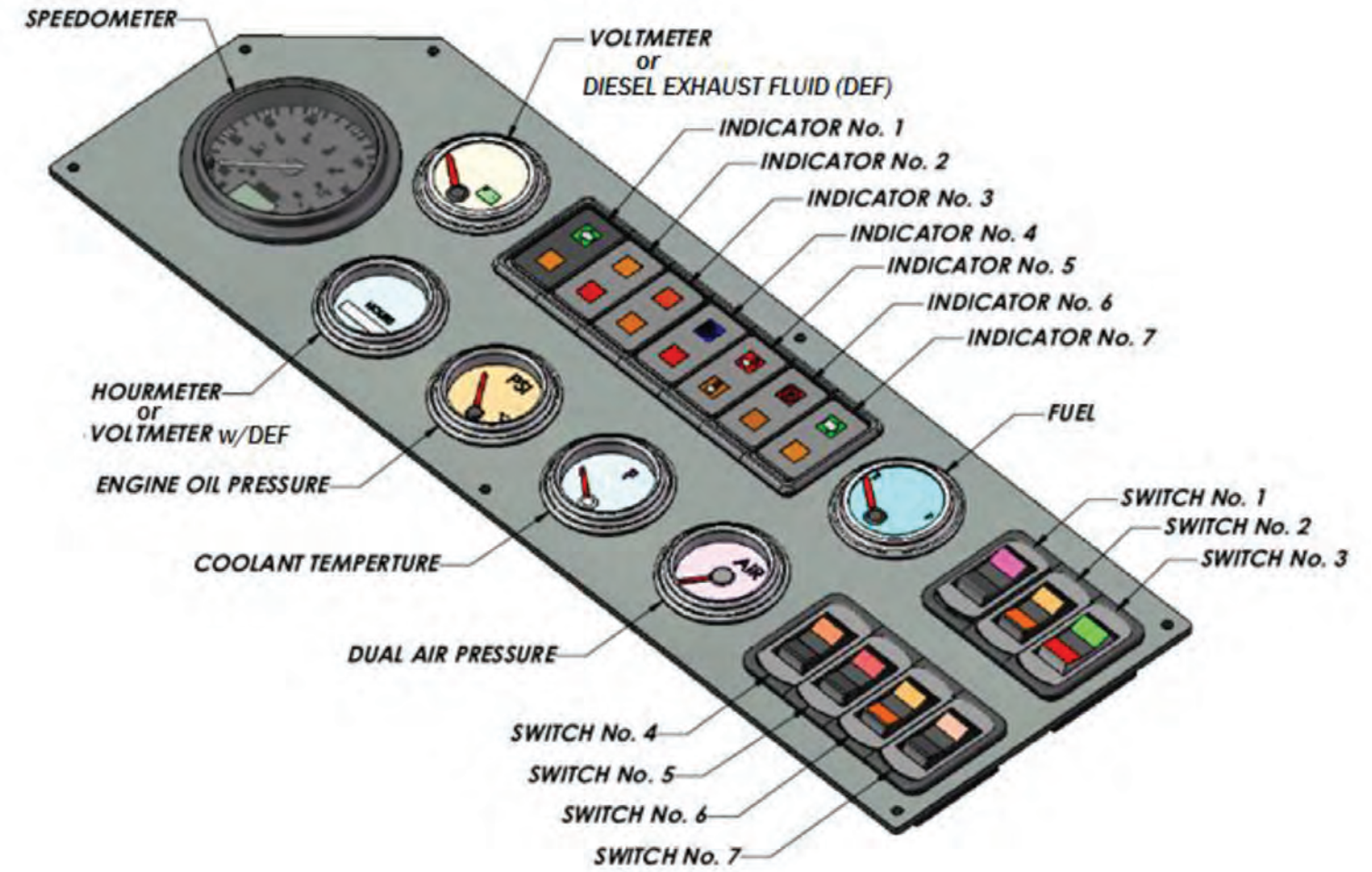

SHIFTER PANEL

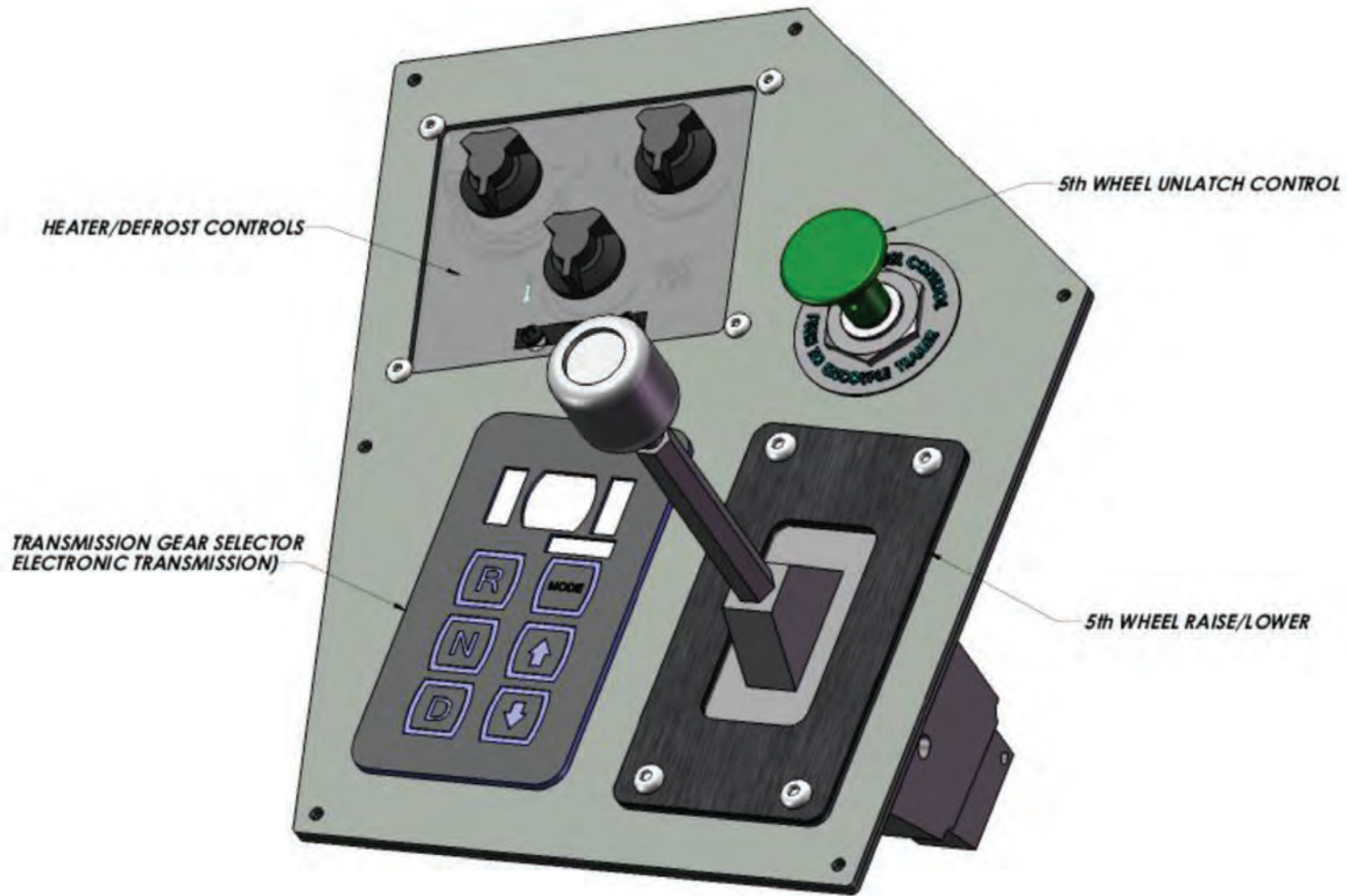

SHIFTER PANEL 2011 MODELS

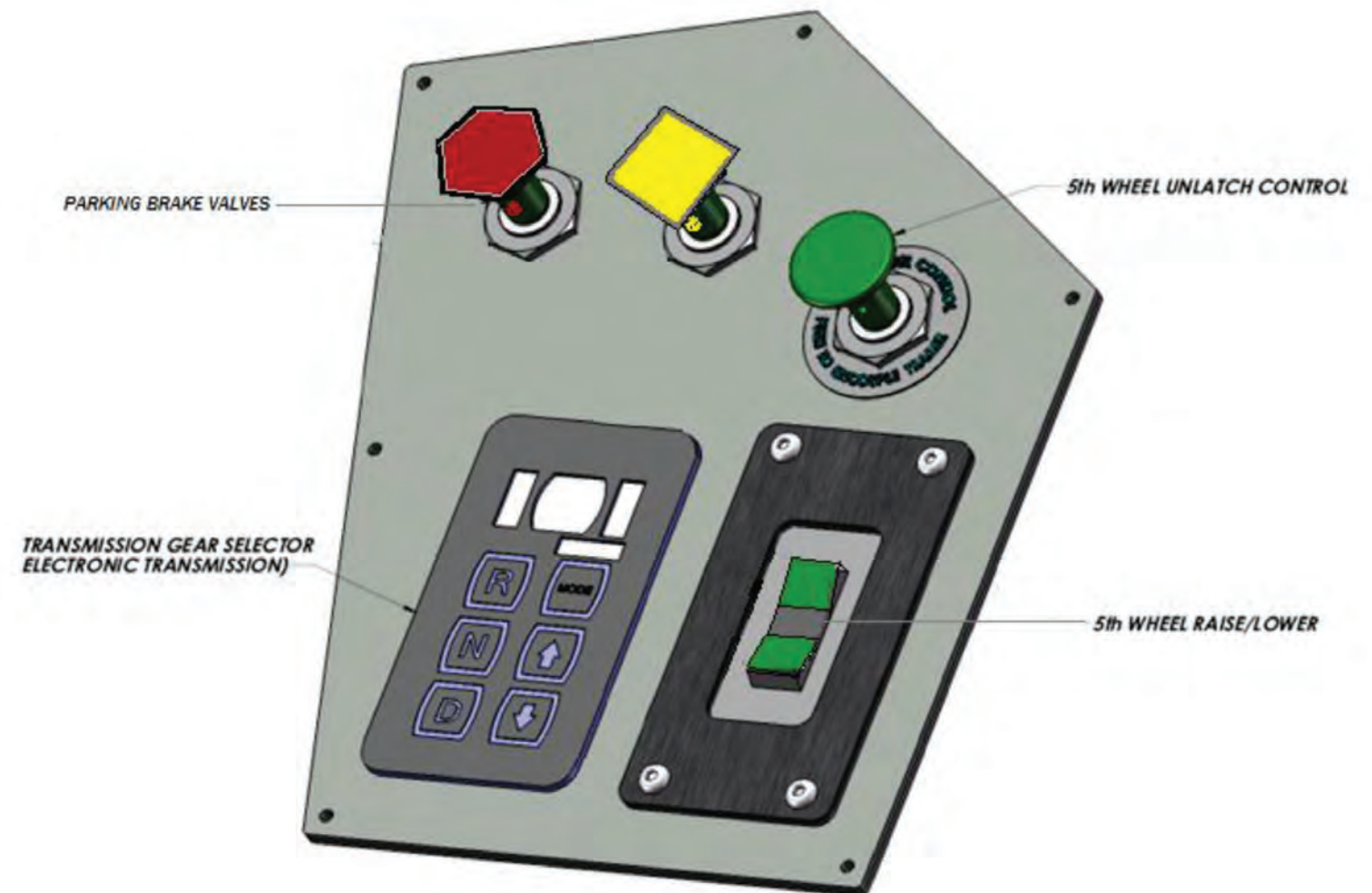

PARKING BRAKE PANEL

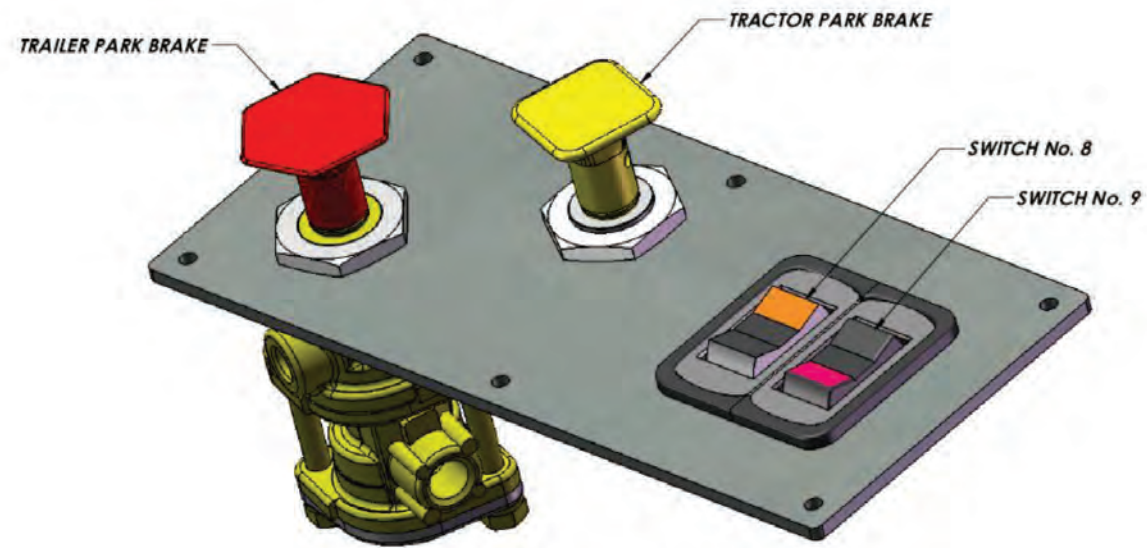

KEY SWITCH PANEL

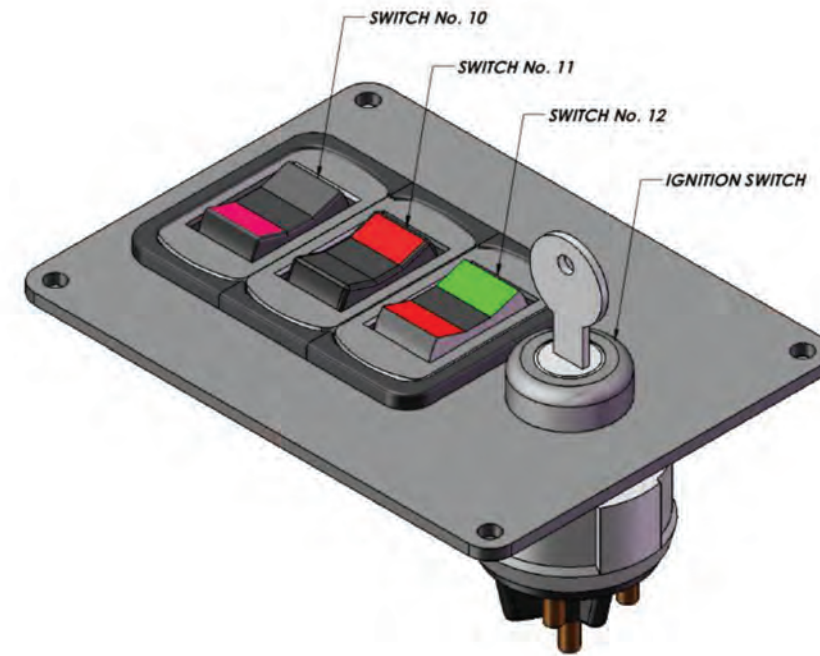

HOURLY METER PANEL 2011 MODELS

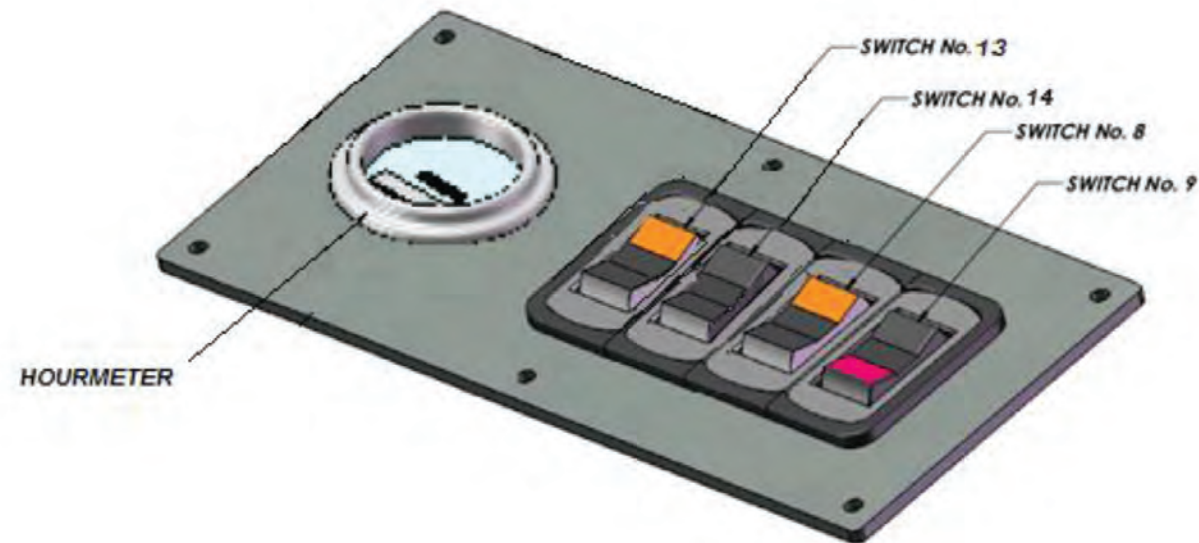

DOOR CONTROL PANEL

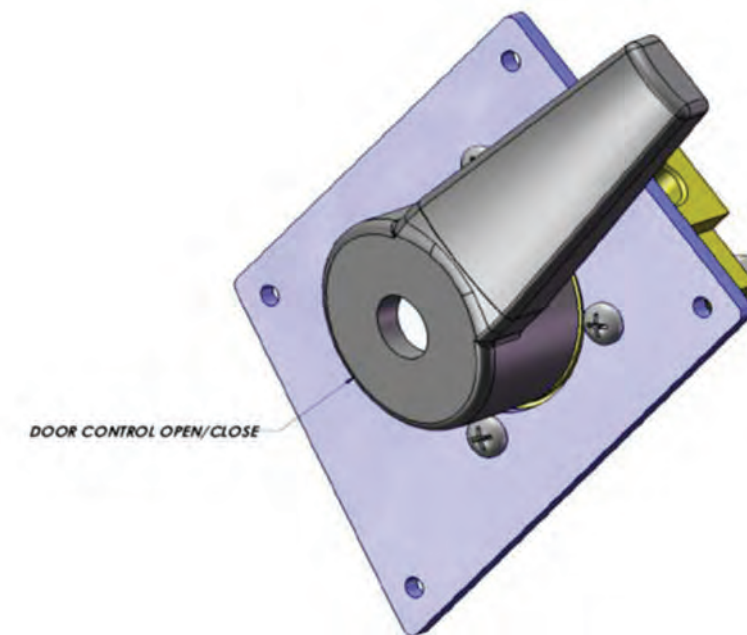

CONTROL AND DISPLAY DESCRIPTION

DASH PANEL 2011 MODELS

INDICATOR NO. 1

Upper Lamp – Left Turn Signal Indicator (green arrow): Indicates left hand turn signal is on when flashing.

Lower Lamp – Wait to Start Indicator (Red): Signals when it is safe to start engine.

INDICATOR NO. 2

Upper Lamp – Check Engine Indicator (amber): Indicates an Engine related problem.

Lower Lamp – Stop Engine Indicator (red): Indicates immediate need to stop engine.

INDICATOR NO. 3 (CERTIFIED ENGINE)

Upper Lamp – High Exhaust System Temperature (HEST) Indicator (amber): Indicates high exhaust temperatures may exist.

Lower Lamp – Diesel Particulate Filter (DPF) Indicator (red): Indicates that the DPF requires Regeneration within the next 2-6 hours.

INDICATOR NO. 4

Upper Lamp – High Beam Indicator (blue): Indicates high beams are on when illuminated.

Lower Lamp – Low Air Pressure (red): Indicates system air pressure is below 70 PSI when illuminated.

INDICATOR NO. 5 (OPTIONAL)

Upper Lamp – Optional switch.

Lower Lamp – Optional switch.

OR

Upper Lamp – ABS Failure (red): Indicates a failure within the ABS system when illuminated.

Lower Lamp – Trailer ABS Failure (red): Indicates a failure within the Trailer ABS system when illuminated.

INDICATOR NO. 6 (OPTIONAL) (CERTIFIED ENGINE)

Upper Lamp – Malfunction (Amber) indicates that some after treatment component is not working properly.

Lower Lamp – Service Transmission (amber): Indicates that the transmission requires service.

INDICATOR NO. 7

Upper Lamp – Right Turn Signal Indicator (green arrow): Indicates right hand turn signal is on when flashing.

Lower Lamp – High Transmission Temperature (amber): Indicates problem with transmission when illuminated.

CONTROL AND DISPLAY DESCRIPTION

DASH PANEL 2011 MODELS

SWITCH NO. 1

Work Lights Switch – Activates a normally rear facing flood light. The switch is two position, up (ON) and down (OFF).

SWITCH NO. 2

Beacon Light Switch – Activates the strobe light.

SWITCH NO. 3

Optional Switches – Air Conditioning, Daytime Running Lights, or Motor-Mirror Switch.

SWITCH NO. 4

Heater Blower ON/OFF Switch – The switch has two positions, on or off.

SWITCH NO. 5

Heater Blower Speed Control – This switch controls the heater blower motor speed, low, medium, or high.

SWITCH NO. 6

Windshield Wiper Control – This control operates the windshield wipers motor speed, low, medium, or high.

SWITCH NO. 7

Windshield Washer Control – This controls the windshield washer pump.

SWITCH NO. 8

Engine Diagnostics/Regeneration Switch – This switch is used to check for trouble codes and for a manual "Parked" Regeneration. (See Page 55 Regeneration).

SWITCH NO. 9

Engine Increment/Decrement Switch – This switch controls the engine idle speed. The switch is a momentary switch with two positions, up (idle RPM higher) and down (idle RPM lower).

SWITCH NO. 10

Rheostat – Controls the brightness of the dash displays.

SWITCH NO. 11

Optional Switch – Dash and Gauge Light Dimmer Switch.

SWITCH NO. 12

Headlight/Running Light Control – This switch controls headlights and running lights on the tractor and trailer.

SWITCH NO. 13

ABS Diagnostic Switch – Activates the ABS diagnostic mode, display any fault codes on indicator lamp.

SWITCH NO. 14

Optional Switch

CONTROL AND DISPLAY DESCRIPTION

GAUGES AND CONTROLS

Speedometer – Indicates vehicle speed in M.P.H or K.P.H. This gauge may also come with an odometer feature built in.

Voltmeter – Indicates the status of the charging system in volts. If the engine is running the gauge indicates the alternator output voltage. If the engine is not running the voltmeter indicates the output voltage of the battery.

Diesel Exhaust Fluid (DEF) Gauge – Indicates the level of the Diesel Exhaust Fluid and contains the Diesel Exhaust Fluid Warning Lamp.

Hour Meter – Indicates engine operating hours.

Engine Oil Pressure Gauge – Indicates the engine oil pressure in PSI.

Coolant Temperature Gauge – Indicates the temperature of the engine coolant in degrees Fahrenheit.

Dual Air Pressure Gauge with Two Needles – Indicates air pressure in the primary and secondary air system in PSI.

Fuel Gauge – Indicates the level of fuel in the fuel tank in 1/4 increments.

Trailer Park Brake – This control activates the trailer air supply and the spring brakes.

Tractor Park Brake – This control operates the parking brakes on the tractor.

Ignition Switch – Switch utilized to start the vehicle, may be keyed or keyless. This switch also activates the interior dash and gauge lights when either the headlights or the running lights are on. The switch has three positions.

Fifth Wheel Unlatch Control – This control disengages the fifth wheel jaw locking mechanism.

Heater Temperature and Flow Control Assembly – Controls the temperature and flow of air for the heating and air conditioning (If Equipped).

Transmission Gear Selector – This control selects the operating range of the transmission. This control may be Electronic Push Button or Lever Type.

TURN SIGNAL, HIGH BEAM AND EMERGENCY FLASHER CONTROL

The column mounted control on the TICO tractor has three functions. It is located on the left hand side of the steering column.

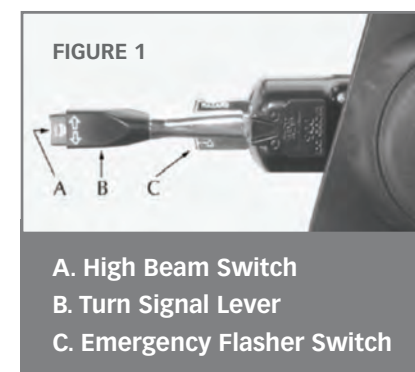

FIGURE 1
A. High Beam Switch
B. Turn Signal Lever
C. Emergency Flasher Switch

1. Moving the lever forward ("B") activates the right turn signal.
2. Moving the lever to the rear activates the left turn signal. The turn signal is not self cancelling and must be returned to the center (off) position manually after it is engaged. The green arrows on the dash panel light up and flash when the switch is activated.
3. The button on the end of the lever ("A") operates the high beam lights. The headlights must be on for the switch to work. When the high beam headlights are on, the high beam indicator on the dash will light up.
4. The pull out switch under the lever ("C") activates the emergency flashers. Pulling out on the switch turns the flashers on. To turn the flashers off, move the turn signal lever forward or backwards.

STARTING THE VEHICLE

The standard ignition switch on the TICO tractor is a key type similar to the kind found on Automobiles. Push button and other types of ignition switches are installed as optional equipment.

KEY TYPE IGNITION

There are three positions; ACCESSORY, OFF, and RUN/START. The full left (counter clockwise) position is the ACCESSORY position. The second position to the right (clockwise) is the OFF position. The third position to the right (clockwise) is the RUN/START position. The RUN/START position is used to engage the starter motor. Moving the switch to the full right position engages the starter and upon release of the key, the switch automatically stays in the RUN position. The ACCESSORY position activates the tractor's electrical accessory circuit. The OFF position cuts all power to the electrical system and shuts down the engine.



NOTICE — The Off position on the standard three position key type switch is designed to function as the engine stop. There is no other engine stop device other than the ignition switch on the standard TICO tractor.

KEYLESS TYPE IGNITION

Keyless ignition switches are optional on TICO tractors. Operation is the same as a key type just without a key needed.



NOTICE — If the engine does not start within 30 seconds release the starter switch and wait 3 minutes to allow the starter motor to cool. If after 3 repeated attempts, the engine still fails to start, stop and determine the cause. The starter motor may be damaged by repeated attempts to start the engine.

PARKING THE VEHICLE

(See page 35, Transmission) (See page 31, Parking Brake)

Standard TICO tractors are equipped with an Allison automatic transmission and spring operated parking brakes. Allison transmissions are unlike an automobile transmission in one important regard. They do not have a park position. When parking your TICO tractor there are some important rules that must be followed.



DANGER — Failure to observe the following rules when parking the vehicle may result in serious injury or death.

1. Always apply the parking brake.
2. Always place the transmission shifter selector in the "Neutral" position and apply parking brake before exiting cab.
3. Never park a tractor trailer combination unless the trailer parking brakes are operational and applied.

AIR BRAKE SYSTEM



NOTICE — The Off position on the standard three position key type switch is designed to function as the engine stop. There is no other engine stop device other than the ignition switch on the standard TICO tractor.



NOTICE — Do not allow moisture to collect in the air tanks. The air tanks must be drained daily. Failure to drain the air tanks can damage the air brake system.



DANGER — Brakes must be kept in proper working condition. Operating a vehicle with poorly maintained brakes or worn out brakes can cause a loss of vehicle control. This may lead to serious injury or death. Never operate the vehicle unless the brakes are working properly.



TICO tractors come equipped with pneumatic (air) brake systems. This system has two basic parts, the service brakes, and the spring parking brakes. The service brakes are the part of the system that the driver uses when he operates the foot operated treadle valve (or foot pedal) in the cab (**Item A**). The service brakes are the primary brakes used by the operator. The service brakes require air to operate. If there is insufficient air in the system, the service brakes will not operate.

The spring brakes are used for parking the vehicle. They are also called the parking brakes because the parking brake control applies the spring brakes. The spring brakes use the mechanical force of a spring to operate. They do not need air to operate, but they do need air to be released. If there is a loss of pressure in the system, these brakes will automatically apply. This is why the spring brakes are sometimes called "emergency" brakes. Remember, a system pressure of 70 PSI is required to ensure parking brakes are fully released.

LOW AIR PRESSURE INDICATORS

When air pressure in the brake system is below 70 PSI, the warning buzzer will sound and the LOW AIR warning indicator on the dash panel will light up. The air pressure gauges should indicate low air pressure in the system. The warning buzzer will shut off after air pressure has reached 70 PSI. If the warning light and buzzer do not shut off at least 5 minutes after start-up, shut the engine down and determine why the air system is not charging. If the Low Air indicator light or buzzer indicates a loss of air pressure while driving, the vehicle should be stopped immediately. The vehicle should not be operated until the air system is repaired and functioning properly.



DANGER — Do not operate the vehicle if the air brake system is not working properly.

SERVICE BRAKES

The Service Brake system is controlled by a foot operated treadle valve (foot pedal) in the cab. This is the left hand pedal, located to the right of the steering column. The amount of foot pedal pressure determines the amount of air pressure delivered to the brakes. The more pressure on the treadle valve (pedal), the more braking force applied. The service brakes should be applied in smooth constant applications. They should not be pumped or fanned while slowing or stopping the vehicle. Even in an emergency stop situation, the service brakes should not be rapidly "pumped".



WARNING — Air brakes do not respond like the brakes in a car, and pumping them in an emergency stop is not advised. Rapidly "pumping" the brakes is more likely to use up all of the air in the system and cause the spring brakes to apply and lock the rear wheels. This will cause an out of control skid.

While the engine is running, the air compressor replenishes the brake system air supply. This air supply provides the pressure necessary to operate the service brakes. The service brakes require at least 90 PSI to operate effectively. If the system is not up to at least 90 PSI, there may not be enough air in the system to stop the vehicle. Several hard brake applications can quickly deplete the pressure in the air system and could possibly cause the pressure to drop below 70 PSI. If this happens the spring brakes will apply automatically, possibly causing the operator to lose control of the vehicle.

SERVICE BRAKES (CONTINUED)

The service brake system is integrated with the parking brake system. Should the service brake system fail because of a lack of air pressure (below 70 PSI), the spring brakes will automatically be applied for emergency braking.



WARNING — Always connect both trailer air lines when towing a trailer. Failure to connect both the trailer service (BLUE), and the trailer supply (RED) air lines greatly reduces Operation braking ability of the tractor trailer combination and creates a serious hazard. This increases the possibility of an accident and could result in serious injury or death.



WARNING — Never operate the vehicle when system air pressure is below 90 PSI there may not be enough air in the system to stop or slow the vehicle. Have the brake system checked by a certified air brake mechanic if there is any doubt about the brake system performance.

ABS

Some trucks may be equipped with the Antilock Braking System (ABS). The ABS system is designed to prevent wheel lock up during hard braking. Trucks equipped with ABS will have an indicator light located in dash panel number one. The indicator light will warn the operator if there is a potential problem in the system. Trucks should not be operated if the indicator light is on. Contact your nearest TICO dealer for qualified service on the ABS system. Trucks built with ABS after March of 2002 will have the capability to check the trailer for a properly operating system. After connecting a trailer to the truck, the system will run a diagnostics check. If a problem is detected with the trailer side of the ABS system a trailer warning indicator light on the dash will illuminate.

Trouble-shooting or clearing fault codes is performed at the EC module mounted to the PDC panel on the left frame rail or on top of transmission.

TRACTION CONTROL

Automatic traction control (ATC) is available as an option on trucks equipped with the Antilock Braking System. When activated, the ATC active/warning lamp will be on and the system will limit wheel spin during hard acceleration. The system is activated by turning on the ATC enable/disable switch located on the dash. During activation, the warning lamp will blink to advise the driver that drive-wheel spin is occurring.

ATC can be disabled while the vehicle is stationary or in motion. However, ATC will not re-enable until the vehicle comes to a complete stop, even with the switch turned to the enable position.



DANGER — Never operate the vehicle if the truck or trailer ABS warning (indicator) lights remain illuminated.

PARKING BRAKE

TICO tractors are equipped with spring brakes for parking. The parking system is operated manually by a cab mounted parking brake control valve. The purpose of the parking (spring) brakes are to hold the vehicle while in the parked position.



WARNING — Never apply the parking brake during normal driving. This could possibly cause an uncontrolled vehicle stop.

TRACTOR PARK BRAKE AND TRAILER PARK BRAKE CONTROLS

NOTICE — Air pressure in the system must be at least 90 PSI before the Parking Brake Control or the Trailer Air Supply Control can be pushed in (releasing the spring brakes).



NOTICE — If the tractor air system is completely discharged, the Trailer Parking Brake Controls will be applied. The trailer parking brake should not be released until the tractor has sufficient air pressure.

MANUALLY RELEASING TRACTOR SPRING BRAKES (CAGING)

When air pressure in the system drops below approximately 43 PSI, the spring Operation parking brakes will apply automatically. To release the spring brakes, the air pressure must be returned to 70 PSI. If the system cannot be recharged and the vehicle must be moved, the spring parking brakes can be released manually (caged). To release the spring brakes, the actual spring in the brake canisters must be mechanically compressed. A release stud, or spring caging tool, must be used to manually compress the brake chamber.

MANUALLY RELEASING TRACTOR SPRING BRAKES (CAGING) (CONTINUED)



DANGER — Never manually release (cage) the spring brakes before the wheels are properly blocked. If the wheels are not properly blocked before releasing the spring brakes, the vehicle may move unexpectedly. This could result in serious injury or death.

The following steps can be used to release the standard (3030) brake chambers used on most TICO tractors. If your vehicle is equipped with other optional brake chambers, refer to that manufacturer's operation or service manual.

1. Shut the engine off and place vehicle in "Lock-Out – Tag Out" condition.
2. BLOCK ALL wheels front and rear to prevent the vehicle from rolling forward and backwards.
3. Determine whether the chamber has an internal (Figure 1) or external (Figure 2) caging tool. Proceed to step 4 with an externally mounted tool. Step 8 for internal types.
4. Remove the access plug from the brake canister.
5. Insert the caging tool into the access hole, "T" end first.
6. Turn the caging tool 1/4 turn to engage with the slot on the pressure plate.
7. Try to pull the caging tool out, it should not pull out. If it does repeat steps 5 and 6.
8. Thread the nut and washer down onto the threaded end of the caging tool all the way to the canister.
9. Tighten the nut until the threaded portion of the release tool is out. It should extend approximately 3" out of the nut.
 - 3.00 inches – Type 2430 and 3030 Chambers
 - 4.00 inches – Type 3036 and 3636 Chambers

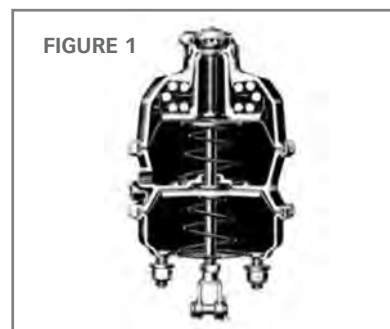

FIGURE 1

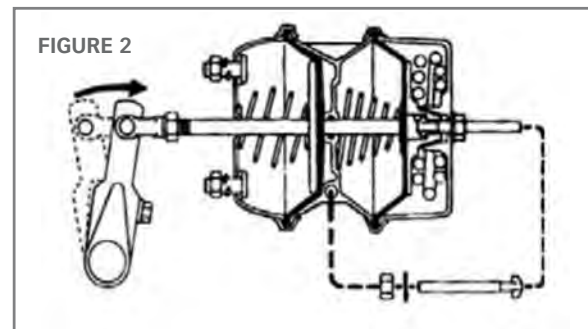

FIGURE 2



CAUTION — Never use an impact wrench to tighten the nut onto the release bolt. Never exceed the above lengths and never exceed 50 lbs-ft of torque on the release nut or the chamber may be damaged.

TRAILER BRAKES

TICO tractors are designed to use the trailer's brakes when towing trailers. All TICO tractors are equipped with a trailer Supply air line and a trailer Service air line. The service line is BLUE. The trailer air supply line is RED. When the vehicle is towing a trailer and the service and supply lines are connected to the trailer, the trailer brakes become part of the tractor's brake system. The tractor service brakes control the trailer service brakes. The tractor parking brake control operates the tractor spring brakes. The trailer air supply line supplies air to the trailer and releases the trailer spring brakes. This is why it is critical that the operator always connect both air lines to the trailer.

TRAILER AIR LINES

If only the supply air line is attached to the trailer, the trailer service brakes will not operate. The tractor service brakes will be doing all the braking for the combination and braking distances will be dramatically increased. Without the trailer service brakes working, jack-knifing and loss of vehicle control is much more likely during heavy braking.



WARNING — Always connect both trailer air lines when towing a trailer. Failure to connect both the trailer service (BLUE) and the trailer supply (RED) air lines greatly reduce braking ability of the tractor trailer combination and may create a serious hazard. This increases the possibility of an accident and could result in serious injury or death.

ENGINE

TICO tractors come equipped with a variety of engines. TICO provides the engine manufacturer's operation manual with each vehicle. It is the operator's responsibility to read the engine operation manual and follow all instructions provided by the engine manufacturer.

Engine performance is very important to the efficient operation of the TICO tractor. Failure to properly maintain and operate any engine can lead to very costly repairs and extensive down time. **KNOW YOUR ENGINE AND MAINTAIN IT!** If you did not receive an engine operation manual, contact your TICO dealer.



NOTICE — This manual only contains basic information on engine operation that applies specifically to the TICO Pro-Spotter tractor.



CAUTION — Failure to read and follow engine manufacturer's instructions regarding engine operation may lead to severe engine damage or loss of manufacturer's warranty. Read the Engine Operation Manual before operating this vehicle.

STARTING THE ENGINE



DANGER — Never attempt to start the vehicle from any position other than the driver's seat; attempting to start the engine in other manner may cause the vehicle to move uncontrolled and cause serious injury or death.



WARNING — All TICO tractors are designed to only start when the transmission is in NEUTRAL. If the vehicle you are operating starts while it is in gear, DO NOT OPERATE THE VEHICLE. Shut the vehicle down and have the neutral lock-out switch repaired before operating the vehicle.

The following is provided as general guideline information. Always follow all instructions provided in the engine manufacturer's operation manual. Different makes and models of engines have different operating characteristics and requirements. There are some important guidelines to follow when starting any TICO equipped with a diesel engine. To start a vehicle equipped with the standard electrical starting system, follow these steps:

STARTING PROCEDURE



NOTICE — All TICO tractors are designed to start in NEUTRAL ONLY. The starter should not operate if the vehicle is in any other gear.

1. Set the parking brake.
2. Place the transmission control in NEUTRAL.
3. Apply the service brakes using the floor mounted treadle valve and hold the brakes in this position.
4. Insert the ignition key into the switch and rotate the key clockwise to the RUN position.
5. Wait for the "Wait to Start" light on the dash to go out if the vehicle is equipped with one.
6. Turn the key to the start position. When engine starts, release the key and allow the switch to remain in the Run position.



CAUTION — If the engine does not start within 30 seconds, release the starter switch and wait 3 minutes to allow the starter motor to cool. If after 3 repeated attempts, the engine still fails to start, stop and determine the cause. The starter motor may be damaged by repeated attempts to start the engine.

ENGINE SHUT DOWN

Diesel engines generate large amounts of heat. Internal engine parts on any diesel engine need to cool down before the engine is shut off. The operator should allow the engine to idle for at least 3 minutes prior to shutting the engine down. This cool down period allows the coolant to dissipate internal engine heat. Shutting a hot engine down without a cool down period may cause an immediate and excessive increase in engine temperature. This could severely damage internal engine components.



NOTICE — Always refer to the engine operation manual for complete information on engine shut down procedures.

SHUT DOWN PROCEDURE

1. Place transmission in neutral.
2. Set parking brake.
3. Allow engine to idle at low idle for at least 3 minutes.
4. Turn ignition switch to OFF position.
5. Make sure all electrical accessories and lights are off and the vehicle is in neutral.



NOTICE — Failure to follow engine manufacturers guidelines regarding engine shut down procedures may cause severe engine damage.

ENGINE OIL

Always refer to the engine operation manual for complete information on engine oil requirements. Service intervals, oil types and refill quantities are all covered in the engine operation manual. **READ IT!**

TRANSMISSION

Standard tractors are equipped with an Allison Automatic Transmission. These heavy duty transmissions are designed for stop and go operation. An Allison Transmission operator's manual is provided with every TICO. This manual provides important information on operation of the Allison transmissions.

The following information can be found in your Allison Operator's Manual:

1. Gear Selection
2. Shifting the Transmission
3. Driving Tips
4. Care and Maintenance
5. Check Oil Level



NOTICE — The operator of this vehicle must read and follow the instructions in the Allison Operator's Manual. Failure to do so may lead to serious vehicle damage and personal injury.

The Allison transmissions do not have a "PARK" position like an automobile transmission. For information on how to properly park your TICO, see the following sections in this manual:

- *Parking the Vehicle (Page 28)*
- *Parking Brake (Page 31)*

HYDRAULIC FIFTH WHEEL LIFTING SYSTEM

The standard fifth wheel lifting system on TICO tractors is hydraulically operated. A P.T.O. and hydraulic pump mounted on the transmission provide the hydraulic power to operate the Hydraulic Fifth Wheel Lifting System. The Fifth Wheel is mounted to a hydraulically operated "Boom". This "Boom" assembly is attached to the frame at a pivot behind the cab. The system operates like a large hydraulic floor jack.

The following are general operating instructions and may not apply to your particular vehicle. If there are any questions regarding the operation of your vehicle or a particular option, contact your TICO dealer.

5th WHEEL RAISE/LOWER CONTROL OPERATION – The hydraulically operated boom can be controlled by a switch inside the cab. These controls are located on the console to the right of the seat and next to the shift lever.



DANGER — Never raise or lower the boom while the tractor and trailer combination are moving. Raising the boom while the tractor and trailer are moving creates a "roll over" hazard and may cause the vehicle to roll over, possibly resulting in injury or death. **DO NOT OPERATE THE BOOM CONTROL LEVER WHILE THE VEHICLE IS MOVING A TRAILER.**

To Raise Fifth Wheel – To raise the boom the engine must be running. Pushing the lever to the "UP" position, indicated on the boom operating lever, raises the fifth wheel. To increase the rate of travel of the boom, the engine may be idled higher while the vehicle is in NEUTRAL ONLY.

To Lower Fifth Wheel – To lower the boom, the engine must be running, the transmission in NEUTRAL. Pulling the boom control lever to the "DOWN" position, marked on the boom operating lever, lowers the boom and fifth wheel. To increase the rate of travel of the boom, the engine may be idled higher while the vehicle is in NEUTRAL ONLY. Standard configuration of the boom allows both power up and down capability.

FIFTH WHEEL UNLATCH CONTROL VALVE

The TICO tractor comes standard with an air operated fifth wheel unlatch cylinder. The cylinder is operated by a "push type" valve located on the right hand console behind the shifter. Pressing the fifth wheel unlatch valve opens the king pin jaws in the fifth wheel. After the jaws are opened, they remain open until the fifth wheel is connected to a trailer kingpin.



NOTICE — When pulling out from under a trailer, the control must be depressed and held until the fifth wheel is clear of the trailer king pin.



NOTICE — The following information is for reference only. TICO Manufacturing highly recommends using the following information to create procedures that match your particular application and vehicle. It is the operator's responsibility to ensure that proper trailer moving procedures are used for a particular situation and vehicle application.

1. Maintain optimum tractor air pressure (120 PSI). The fifth wheel should be in the FULL DOWN position. Be absolutely positive that the fifth wheel jaws are in the UNLATCH position by depressing the unlatch control valve located to the right of the shifter.
2. Line the tractor up to the front of the trailer by centering the fifth wheel to the center line of the trailer. Make sure that the tail of the fifth wheel is BELOW the trailer skid ramp.
3. Back the tractor UNDER the trailer until the ENTIRE fifth wheel DISAPPEARS UNDER the front edge of the trailer floor/skid plate.
4. With your foot firmly on the brake treadle and the tractor shift lever in NEUTRAL, move the boom control lever to the UP position and raise the trailer until the trailer support is JUST OFF THE GROUND. DO NOT raise the trailer any more than a few inches to provide clearance between the trailer landing gear and the ground at this step.
5. After you have obtained adequate ground clearance at the trailer landing gear, place the shift selector in REVERSE, release your foot from the brake treadle and back FIRMLY into the kingpin jaws until you feel full engagement. REMEMBER, the latching jaws in the fifth wheel MUST BE FULLY IN THE UNLATCH POSITION BEFORE attempting kingpin engagement.
6. Place the transmission shift lever into a forward drive gear and do a pull test. (FORWARD – BACK– FORWARD) BE PREPARED to stop if the fifth wheel jaws have not fully latched to avoid pulling out from under the trailer and dropping it.
7. Place the shift lever in the NEUTRAL position and raise the boom using the boom control lever. Raise the fifth wheel to the necessary height to maintain ground clearance while towing the trailer to the new location. Be aware of potential overhead damage to a trailer if it is raised too high.
8. Once proper trailer height is reached, apply the tractor parking brake. Now hook BOTH the trailer emergency and service airlines to the trailer (blue & red airlines) and plug in the trailer electrical cable.
9. With the brake treadle FULLY applied, push in BOTH the parking brake control (yellow) and the trailer air supply (red), this will charge the trailer air supply and release the trailer spring/parking brakes.
10. After the tractor air system is fully charged, move the transmission shift lever to the proper gear and release pressure on the foot operated brake treadle and allow the vehicle to roll a VERY SHORT distance and then depress the brake treadle again to stop the vehicle. This procedure will insure that the service brakes on the trailer are working properly. NOW, and ONLY NOW, are you ready to move ("SPOT") the trailer.

11. Once the trailer is relocated and the vehicle combination is completely stopped, place the shift lever in NEUTRAL and pull out on the trailer air supply control (red). This will apply the trailer parking brakes only. The parking brake control (yellow) should remain "in", with the tractor parking brake released.
12. Using the boom control lever, lower the trailer until the trailer supports are resting completely on the ground.
13. Disconnect and STORE the air lines and electrical cable.
14. DEPRESS and HOLD the fifth wheel unlatch control valve as you slowly pull away from the trailer. Once the fifth wheel is completely clear of the kingpin, release the fifth wheel unlatch control and go to the next trailer.



WARNING — When the tractor is operated on public streets or highways, the 5th wheel manual secondary lock **MUST** be engaged. The secondary lock is engaged by removing the hairpin clip on the lock handle allowing the lock to pivot behind the locking yoke. The fifth wheel **MUST** be in the DOWN position to operate the vehicle on public streets or highways.



WARNING — Never raise or lower the boom while the vehicle has a trailer attached and is in motion.



WARNING — Never tow trailers without BOTH the service and emergency brake lines connected to the trailer. Never tow trailers without functioning service and emergency brake systems. Operating the vehicle while towing trailers without functioning trailer brake systems may lead to loss of control of the vehicle, serious injury or death.



WARNING — Never tow a trailer above the minimum height required to have the trailer landing gear clear the ground. Lifting the trailer too high drastically increases the center of gravity of the trailer and increases the chance of a roll over.

TOWING THE VEHICLE

Towing a vehicle requires special equipment and training. TICO Manufacturing recommends that a professional towing service be used when towing a disabled TICO.

The best way to tow a TICO tractor is with the rear wheels lifted off the road. This prevents any possible damage to the transmission and drive train. Towing the vehicle with the rear wheels lifted avoids having to disconnect the driveline or axle shafts. Also, towing with the rear wheels lifted does not require the spring brakes to be caged unless there are spring brakes on the front wheels. If it is impossible to tow the vehicle with the rear wheels lifted, be sure to follow the steps listed below, "Towing Vehicle with Front Wheels Suspended".



CAUTION — Some TICO's are equipped with "Off Highway" tires. Tire damage may occur if towed on road.

TOWING VEHICLE WITH FRONT WHEELS SUSPENDED

It is not recommended to tow a vehicle with the front wheels lifted and the rear drive wheels on the road. This practice may result in serious vehicle damage. Pay close attention to the following rules to prevent vehicle damage if you must tow your TICO with the rear wheels on the road.



WARNING — Always obey the following when towing a TICO tractor with the front wheels lifted and the rear wheels on the road.

1. Always use a rigid towing bar or properly restrain the towed vehicle. Using a chain or cable to tow the vehicle is not recommended.
2. Always disconnect the drive line to the rear drive axle(s), or remove all axle shafts from all rear drive axles.
3. Always cage the spring brakes on all rear drive wheels. (See page 32, *Manually Releasing Spring Brakes*) A loss of air pressure could occur while towing the vehicle. This would apply the spring/parking brakes and lock the rear wheels on the towed vehicle.



WARNING — When manually releasing spring brakes, make sure that the vehicle wheels are properly blocked. If the wheels are not blocked, the vehicle could move suddenly when the spring brakes are released and cause severe injury.



WARNING — If the disabled vehicle is connected to a tow vehicle before the spring brakes are released, make sure that the tow vehicle's parking brakes are applied and its wheels are blocked to prevent movement.

AXLES

TICO tractors may be ordered with a variety of axle configurations, makes and models. It is important to refer to the axle manufacturer's information for your specific axles. You can obtain axle operation and maintenance information from your local TICO dealer. The following is general axle information and may not apply to your particular axle.



NOTICE — This manual does not contain complete operational information on any axle. The operator must obtain and refer to the axle manufacturer's information on operation, service, and maintenance.

Normally, axle operating temperatures will not exceed more than 100 degrees Fahrenheit (37 deg. Celsius) above ambient temperature. High axle operating temperatures will significantly increase the rate of lubricant oxidation and shorten the effective life of the lubricant. This makes more frequent changes necessary.

REAR AXLES WITH LOCKING DIFFERENTIALS

TICO tractors may be equipped with a variety of special axle and differential combinations. Because of the effect of special differentials on vehicle operation, it is important to understand how your particular differential operates. Locking or limited slip differentials are not standard on TICO tractors. If you do not know if your vehicle is equipped with a special axle and differential, contact your TICO dealer.

"NO SPIN" POSITIVE LOCKING DIFFERENTIAL

TICO tractors may be equipped with an optional "No Spin" differential. This locking differential has very special operating characteristics. *IT IS VERY IMPORTANT FOR THE OPERATOR OF A VEHICLE EQUIPPED WITH THIS FEATURE TO OBTAIN AND FOLLOW ALL OF THE OPERATION AND MAINTENANCE INFORMATION PROVIDED BY THE DIFFERENTIAL MANUFACTURER.* Contact your TICO dealer for assistance on operating and maintaining this differential.

CAB TILTING AND LOWERING

The tractor comes equipped with an electrically operated cab tilt system as standard equipment. Under power assist, the cab can be tilted to 35 degrees. At 35 degrees the safety support bar is automatically engaged.

The cab can be tilted MANUALLY TO 90 degrees if needed. This requires that the tilt cylinder be disconnected, and that a suitable hoist be used to tilt the cab to the 90 degree position.

All tractors come standard with a cab air suspension. These units are designed to work with the power cab tilt, and unlatch automatically. If the unit is not equipped with cab air suspension as an option, the cab hold down latches will also operate automatically when tilting the cab.

The electric cab tilt is designed to tilt the cab to 35 degrees at which point the cab safety support bar is automatically engaged. The tilt system is not designed to provide a safety prop at any point other than 35 degrees.



DANGER — Never work under the cab unless the cab safety latch is properly engaged. The cab could fall and cause serious injury or death.

TO TILT CAB

In most cases, the cab tilt control lever is located on the right hand frame rail. The safety support bar release handle is located on the Right hand rail, within reach of the Cab Pump lever/switch.



WARNING — Stand clear of the rear of the cab and ensure that the cab does not strike you when it is being raised or lowered. Before tilting cab, check the front of cab for obstructions. Cab will move forward when raised.



WARNING — Ensure that the safety support bar is properly engaged before working under the cab. The safety support bar must be able to move freely to engage automatically. Always check the safety support bar before working under the cab and make sure to properly maintain this important safety system.

1. Locate the cab pump control switch and safety latch release handle.
2. Pull the safety latch release handle and hold the handle to the rear.
3. While holding the handle to the rear move the tilt control switch to the "UP" position.
4. After the cab has travelled about 15 inches, release the safety latch handle and continue tilting the cab.
5. As the cab approaches the 35 degree position, watch for the safety latch to drop over the lock position on the right side of the frame. STOP!
6. After the safety latch has dropped over the cab stop, move the tilt control lever to the "DOWN" position and lower the cab slightly until the safety latch rests fully on the cab stop.
7. Make sure that the Safety latch is resting properly on top of the cab stop. Pull on the Safety Latch Release Handle and ensure that the safety latch is secure, it should not move with the weight of the cab on the stop.

TO LOWER CAB

1. Move the cab tilt switch to the "UP" position and raise the cab slightly until the safety support bar is free from the top of the cab stop.
2. Pull the safety support bar release handle to the rear and hold in the rearward position.
3. Move the tilt lever to the "DOWN" position with the safety support bar disengaged and allow the cab to lower onto the rear cab latch.
4. Hold the cab tilt lever in the down position for 5 seconds after the cab has come to a rest on the lower latch units to ensure that the mechanical cab latches are fully engaged.



WARNING — Ensure that the cab latches are fully engaged after lowering the cab. Do not operate a truck unless the cab latches are engaged.

ELECTRICAL

ACCESSORY CONNECTIONS

The wiring harness in the TICO is designed to support many vehicle options. These options may or may not already be on your vehicle. If any electrical equipment is installed on the vehicle after it leaves the factory, contact your TICO dealer first. Your dealer can provide you with information on proper electrical modifications and installations. Generally, there will be an accessory location on the harness where you will need it. Do not risk damaging your vehicle or voiding the warranty by making improper and poor electrical modifications, contact your TICO dealer first.

RELAYS / BREAKERS / FUSES

The TICO is equipped with an easily accessible fuse panel. This panel is located below and to the left of the steering column, underneath the dash.

Trucks equipped with an electronic engine will have an additional relay panel located directly above the main fuse panel. (The relay panel can be accessed by removing the first dash panel.)

The fuse panel has a removable cover.

UNDER DASH CIRCUIT BREAKER PANEL

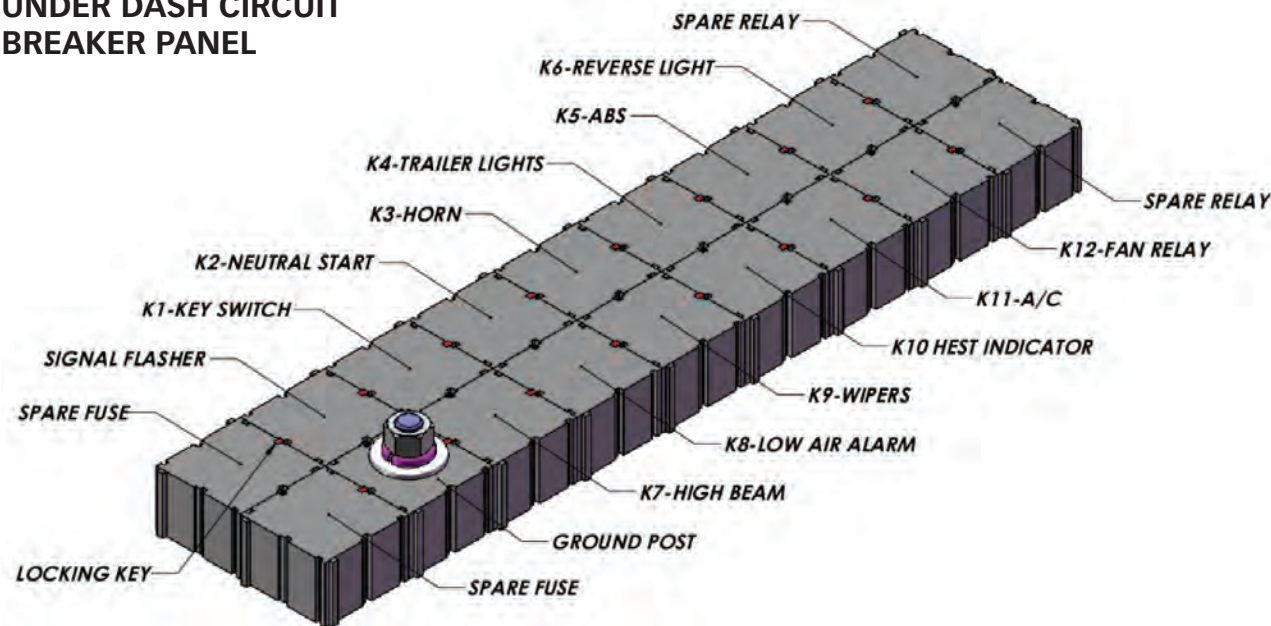

FUSE PANEL

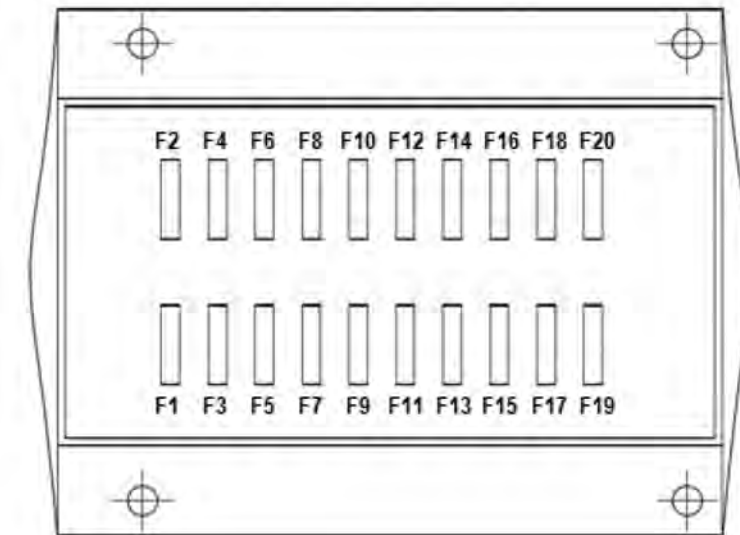

FUSE TABLE		
FUSE #	FUNCTION	SOURCE
F1	SPARE	BATTERY
F2	WORK LIGHTS	BATTERY
F3	FLASHER	BATTERY
F4	HORN	BATTERY
F5	HEADLIGHTS	BATTERY
F6	HVAC / FAN	BATTERY
F7	WIPER	BATTERY
F8	WORK LIGHTS	BATTERY
F9	TAIL LIGHTS	BATTERY
F10	TRAILER LIGHTS	BATTERY
F11	OPTION LIGHTS	BATTERY
F12	SPARE	BATTERY
F13	ENGINE FAN	IGNITION
F14	GAUGES	IGNITION
F15	ABS	IGNITION
F16	ECM	IGNITION
F17	TCM	IGNITION
F18	SPARE	IGNITION
F19	ACCESSORY	IGNITION

INTRODUCTION (MAINTENANCE)

The key to safe and dependable operation of your TICO tractor is proper maintenance. Yard tractors are used in very abusive operations. Moving trailers through rough yards 10 to 24 hours a day can take a toll on even the best built piece of equipment. It is the operator's job to ensure that every time he or she climbs into the cab, that the vehicle is ready to roll, safely and reliably.

Because all spotting applications are not the same, it is critical that a good "Total Maintenance Program" is developed for your particular vehicle and application. A vehicle that runs 24 hours a day in a railroad yard will need a more intensive maintenance program than a vehicle running 8 hour days in a smooth, paved lot.

If you need assistance on determining a good maintenance program, call your TICO dealer for assistance.



WARNING — A vehicle that has not been properly maintained, may not be safe to operate. The operator of a TICO must be satisfied that his/her vehicle has been properly maintained and is in safe working condition, before operating that vehicle. Operating an improperly maintained vehicle may lead to loss of vehicle control, which could severely injure or kill the operator.



WARNING — Vehicle maintenance, other than routine operator maintenance (checking fluids, cleaning, filling fuel tank), should only be performed by a professional, trained mechanic. Many maintenance procedures require special training and tools to be done safely. Attempting to perform maintenance procedures without proper training and equipment may lead to serious injury or death.



NOTICE — The pre-operation checklist or "walk around" ensures that there are no obvious problems with the vehicle (a sample checklist is provided on page 10). This is no substitute for a good Preventative Maintenance program.

LUBRICATION AND FLUIDS

This section contains basic fluid and lubricant requirements and their minimum service intervals for the Standard TICO tractor. It also contains basic information on filter change intervals. If your vehicle has any optional or special factory installed equipment, such as planetary axles or a central lube system, contact your TICO dealer for specific lubrication requirements for your vehicle.

LUBRICATION AND FLUIDS (CONTINUED)

The fluids and lubricants covered in this section are listed below. If a specific lubricant or fluid used on your vehicle is not covered in this section, contact your TICO dealer for the information.

- Automatic Transmission Fluid
- Axle Differential Lubricant
- Coolant / Anti-freeze
- Diesel Fuel
- Engine Oil
- Multi-purpose Grease
- Hydraulic System Fluid
- Diesel Exhaust Fluid

The Lubrication Diagrams on pages 55 and 57 show the location of specific lubrication and fluid points for easy reference.

The Preventive Maintenance Form (on page 49) indicates services that need to be performed at every 250, 500, 1000 and 2000 hour interval. The chart also indicates the type of lubricant or fluid required or indicates the page number where that information can be found.



CAUTION — The maintenance and service intervals in this manual are provided for a reference. These intervals are the maximum allowable on a vehicle used in a normal operation. These intervals may not apply to your specific vehicle application. It is the operator's responsibility to ensure that the vehicle is properly maintained. Failing to maintain a vehicle properly may lead to serious vehicle damage and possibly an unsafe vehicle.



NOTICE — Never add any type of fluid or lubricant unless it is the same grade and type which is currently being used. Mixing of difference lubricant and fluid grades or types should be avoided. If the grade or type of fluid is unknown, the system must be drained and flushed before the new fluid or lubricant is added.

AUTOMATIC TRANSMISSION FLUID

All TICO tractors come with a Transmission Operator's Manual, provided by the manufacturer. This manual covers the specific transmission in your vehicle. Refer to this Transmission Operator's Manual for transmission fluid requirements and service intervals.



NOTICE — TICO Manufacturing requires that the operator of any TICO tractor comply with the transmission manufacturer's transmission fluid requirements. Failure to comply with the transmission manufacturer's requirements for transmission fluid may void the warranty on the transmission and cause severe transmission damage. Contact your TICO dealer if you did not receive a Transmission Operator's Manual with your new TICO.

AXLE LUBRICANT

Axle lubricant requirements vary with maker of the axle and customer requirements. Refer to the axle manufacturer's operator's manual for required specifications and operating information.



NOTICE — Synthetic gear lubricant is available as an option. Contact your TICO dealer if you need more information.



NOTICE — Front axles equipped with optional "WET" wheel seals require the lubricant described previously. They do not use the lithium based grease used on standard front hubs. The fluid in these front hubs needs to be checked every 250 hours.

COOLANT / ANTI-FREEZE

The Cooling system of a new TICO is filled at the factory with the following solution: 50% ethyl-glycol heavy-duty antifreeze with rust inhibitor and 50% water. Coolant system additive must be aluminium compatible.

Proper level of fill for the cooling system is indicated by the presence of coolant in the sight glass of the radiator top tank. It is not necessary to fill the top tank to the filler neck. A 50/50 mixture provides freeze protection down to -34 degrees F. and maintains proper heat transfer properties. This is the recommended solution mixture. Always refer to the Engine Operator's Manual before changing the factory recommended anti-freeze to water ratio in the coolant mixture. Some engine manufacturers have specific coolant mixture requirements needed to satisfy engine warranty requirements. Remember to check and maintain the anti-freeze solution in your TICO tractor regularly. Contact your TICO dealer if you need more information. Some engines, specifically "sleeved" engines, require the use of supplemental coolant additives to prevent liner cavitation. Refer to the engine operator's manual for more information.



WARNING — Never attempt to open the radiator when the engine is hot. Always allow the engine and coolant to cool completely before opening the radiator. Failure to allow the coolant to cool will cause hot coolant to spray from the radiator when it is opened. This could cause severe burns.



NOTICE — The coolant should be tested every 250 hours and replaced every 2000 hours at the very minimum. Exceeding these intervals may damage the cooling system.



NOTICE — A coolant mixture below 30% does not provide adequate corrosion protection and may lead to radiator damage. A coolant mixture above 68% does not provide proper freeze protection and reduces heat transfer capabilities of the solution.

FUEL

All TICO tractors come with an Engine Operator's Manual provided by the engine manufacturer. This manual is for the specific engine in your vehicle. Refer to this Engine Operator's Manual for fuel requirements. *On road certified engines (Cummins ISB's) require use of "ULTRA LOW SULFUR FUEL" ONLY.*



NOTICE — TICO Manufacturing requires that the operator of any TICO tractor comply with the engine manufacturer's fuel requirements. Failure to comply with engine manufacturer's fuel requirements may cause severe engine damage and void the warranty on the engine. Contact your TICO dealer if you did not receive an Engine Operator's Manual with your new TICO.

DIESEL EXHAUST FLUID (DEF) — (EPA ENGINES)

All TICO tractors come with an Engine Operator's Manual provided by the engine manufacturer. This manual is for the specific engine in your vehicle. Refer to this Engine Operator's Manual for Diesel Exhaust Fluid requirements. *On road certified engines require use of Diesel Exhaust Fluid stored in a 5 gallon tank located on the left frame rail directly behind the Diesel Fuel Tank.*



NOTICE — TICO Manufacturing requires that the operator of any TICO tractor comply with the engine manufacturer's Diesel Exhaust Fluid (DEF) requirements. Failure to comply with engine manufacturer's DEF requirements may cause severe engine damage and void the warranty on the engine. Contact your TICO dealer if you did not receive an Engine Operator's Manual with your new TICO.

ENGINE OIL

All TICO tractors come with an Engine Operator's Manual provided by the engine manufacturer. This manual is for the specific engine in your vehicle. Refer to this Engine Operator's Manual for engine oil requirements.



NOTICE — TICO Manufacturing requires that the operator of any TICO tractor comply with the engine manufacturer's engine oil requirements. Failure to comply with the engine manufacturer's requirements for engine oil may void the warranty on the engine and cause severe engine damage. Contact your TICO dealer if you did not receive and Engine Operator's Manual with your new TICO.

TICO MANUFACTURING PREVENTATIVE MAINTENANCE GUIDELINES

CAB INTERIOR

Check Operation of Neutral Start – Move the gear selector to any position other than “N” and attempt to start the engine. The engine should not crank with the selector in any position other than “N”.

Check Operation of All Gauges – With the engine running verify that all gauges are functional.

Check Low Air Buzzer and Light – Apply and release the brake pedal until air pressure drops below 70 PSI. At that point, the low air buzzer and dash warning light should come on.

Check Windshield Wiper Operation – Turn on the windshield wiper and confirm full and smooth travel of the wiper arm. Listen for any noises that might indicate a worn wiper motor.

Check Windshield Washer Operation (If Applicable) – Depress the washer button and confirm the flow and pattern of the washer fluid.

Check Accelerator for Free Operation – Depress and release the foot throttle and check for binding and ease of operation.

Check Horn(s) Operation – Sound electric and air horns (if applicable) to confirm proper operation.

Check Air System for Maximum 130 PSI – Start engine and run at fast idle. Governor should limit system air pressure to 120 psi.

Check Air System for Leak Down – Disconnect the glad hands from the trailer. Run engine at fast idle and allow air pressure to stabilize at 120 psi for at least one minute. Shut off engine and observe dash gauge(s) for 2 minutes. The drop in pressure should not exceed 2 psi over the two-minute period.

Check Operation of Back Up Alarm (If Applicable) – With engine running, move the gear selector to reverse and listen for back up alarm.

Check Operation of Shift Lock Out (MT Series Trans Only, if equipped) – With engine running, air pressure above 90 psi, and the parking brake set, attempt to move the gear selector from any drive gear to reverse without depressing the brake pedal. You should not be able to select reverse.

CHECK HVAC SYSTEM

Blower Motor Operation – With the key on, insure that the blower motor operates at each position of the blower speed switch.

Temperature Control – Confirm proper operation of the temperature control switch.

Auxiliary Fan(s) (If Applicable) – With the key on turn on the auxiliary fans and confirm operation.

Air Conditioner Operation (If Applicable) – With the engine running and the air conditioner control turned on, confirm cooled airflow from the A/C vents.

Defroster Operation – With the engine running and the defroster control turned on, confirm airflow from the defroster vents.

Check 5th Wheel Unlatch Control – With system air pressure above 90 psi confirm that the 5th wheel jaws unlatch and air cylinder activates when dash control is depressed.

Check Operation of Boom – With the engine running at fast idle activate the boom control and insure full extension and retraction.

Check Fire Extinguisher Charge (If Applicable) – If the vehicle is equipped with a fire extinguisher confirm that it is properly charged.

Check Seat Belt Operation – Insure that the seatbelt latch fastens and unfastens properly. Check to see that there are no cuts or tears in the webbing.

TICO MANUFACTURING PREVENTATIVE MAINTENANCE GUIDELINES *(CONTINUED)*

Check Rear Door Operation – Operate the rear door to insure proper operation. When leaving the cab always insure the door control is in the center position. This is so the door can be opened and closed manually.

Check Dome Light Operation – With key on, turn on cab dome light and confirm operation.

Check all Glass and Mirrors – Inspect all glass and mirrors for cracks and breaks.

Check Operation of Windows – Confirm that all sliding windows open and close fully.

CAB DOWN – EXTERIOR

Check Cab Access Steps and Handles – Inspect all steps and grab handles for proper mounting and the absence of cracks.

Clean Heater / AC Filter (If Applicable) – Remove HVAC filter and vacuum or blow clean with low pressure air.

Check Rear Door Bushings – Check rear door bushings and lubricate with a light oil.

Check Gladhand Seals and Trailer Air Lines – Inspect seals for tears and wear. Check air lines for kinks or cracks.

Check Trailer Light Cord (If Applicable) – Inspect light cord for cuts and abrasions. As the lights of the truck are checked confirm that a trailer connected with the light cord also has lights. This can be done either with a trailer connected or with a “test box”.

Check Headlights / Marker Lights – Start engine, turn on light switches and confirm lights are burning.

Check Turn Signals (If Applicable) – With key on, activate the turn signal switch and the flasher to confirm that the turn signals are working.

Check Strobe Light (If Applicable) – With the key on, turn on the strobe light to confirm its operation.

Check Spotlights – With the key on, turn on the spotlight(s) to confirm its operation.

Check Wiper Blades – Inspect wiper blades for tears or excessive wear.

Check Windshield Washer Fluid Level (If Applicable) – Fill washer bottle as necessary.

CAB UP



CAUTION — Keep cab interior clean. Remove all debris from inside of cab.

Check Operation of Cab Tilt Pump – Pull cab release handle and activate cab tilt lever. Cab should rise.

Check Cab Safety Latch – Inspect the cab safety latch. It should drop freely into place to support the cab when it is in the raised position. The lower cab cylinder pin and bracket should be inspected for signs of fatigue.

Check Cab Suspension and Latch – Inspect the linkages of the suspension system for excessive wear and proper alignment. Inspect the air bags for leaks or signs of abrasion. Inspect the lock jaw for excessive wear and proper operation.

Check Intake Ducting for Leaks – Inspect all engine clean air tubes and hoses for leaks. All clamps should be checked for proper torque and all joints should be properly aligned.

Check Radiator for Leaks – Inspect radiator core and tanks for signs of coolant leaks.

Check Radiator Mounts – Inspect radiator mounts for wear or excessive looseness.

Check Coolant Level and Concentration – Check cooling system level. Coolant should be visible in radiator sight glass. It is not necessary for the coolant to be at the top of the sight glass. Test and maintain the proper antifreeze level of concentration as outlined in the appropriate engine operator's manual.

TICO MANUFACTURING PREVENTATIVE MAINTENANCE GUIDELINES (CONTINUED)**CAB UP** (CONTINUED)

Change Engine Coolant – Flush the cooling system and replace with clean coolant of the appropriate concentration.

Check Coolant Hoses and Clamps – Inspect all hoses for abrasion, cracks, holes and routing. Check all clamps for proper torque.

Check Fan Clutch for Operation (If Applicable) – Run engine to confirm that the fan clutch engages at the proper temperature.

Check Engine Cooling Fan for Cracks – Shut engine off if running. Inspect fan blades for signs of cracking.

Check Engine Belts and Tensioner – Inspect belt(s) for cracking and wear. Belt tensioner should be checked for proper operation.

Check Engine and Transmission for Leaks – Perform a visual inspection of the engine and transmission looking for any fluid leaks visible from above.

Drain Fuel / Water Separator – Open the drain valve on the fuel / water separator and allow water to drain from the filter.

Change Fuel Filter / Fuel Water Separator – Replace fuel filter following the instructions in the engine operator's manual.

Check Air Restriction Gauge (If Applicable) – Record reading on gauge, reset, start engine, run to high idle and shut off engine. If reading remains on zero, the gauge may be defective or the intake piping has a leak. The cause must be investigated and the gauge replaced and/or the piping repaired. If the initial gauge reading indicates that the filter should be changed, do so at this time. See the next item on the PM form.

Change Air Filter – The air filter should be changed as needed. If the truck is equipped with a restriction gauge, replace the filter when the gauge indicates it is appropriate.

Change Air Dryer Desiccant (If Applicable) – The desiccant should be changed as needed. Change as soon as water is evident when system air tanks are drained.

Check Exhaust System – Visually inspect all of the exhaust system components for leaks and / or damage.

Check Transmission Fluid Level – With the engine running use the transmission dipstick to check the fluid level per the guidelines in the transmission operator's manual.

Clean Transmission Breather – Confirm that the breather, located on top of the transmission, is clean and the passage is open. Do not spray directly with high pressure or cleaning solvents.

UNDER VEHICLE

Check Steering Gear – Inspect steering gear for fluid leaks and excessive play. Inspect the steering linkage for wear or looseness.

Check Brake Linings and Drums – Visually check linings and drums for wear and cracks. If the lining is 0.25" thick or less in any location the shoes should be replaced or relined.

Check Springs – Inspect leaf springs for cracking or excessive deflection. Inspect spring pins and shackles for wear.

Torque Front Axle Mounting Bolts – Re-torque front axle mounting bolts.

Torque King Pin Draw Key Nuts – Re-torque steer axle king pin.

Check Power Steering Pump – Inspect pump for fluid leaks.

Check Hydraulic Pump – Inspect hydraulic pump for leaks.

Check Starter Mounting and Connections – Confirm that starter mounting bolts are tight. Inspect electrical connections for good contact at starter terminals.

TICO MANUFACTURING PREVENTATIVE MAINTENANCE GUIDELINES (CONTINUED)**UNDER VEHICLE** (CONTINUED)

Check Engine and Transmission for Leaks – Perform a visual inspection of the engine and transmission looking for any fluid leaks visible from below.

Change Engine Oil and Filter – Drain and replace engine oil. Use oil meeting, at least, the minimum specifications provided in the engine operator's manual. Replace the oil filter.

Change Transmission External Filter – Replace external filter.

Change Transmission Fluid – Per component manufacturer's recommendations. Use fluid meeting, at least, the minimum specifications provided in the transmission operator's manual.

Check Engine and Transmission Mounts – Re-torque engine and transmission mounts. Inspect isolator material and replace if deteriorated.

Check Wheel Seals for Leaks – Inspect front and rear hubs for signs of oil leaks. Replace if leaking.

Clean Rear Axle Breather – Insure that the rear axle vent turns freely.

Check Differential for Leaks – Inspect rear axle housing for signs of leaks. Repair as necessary.

Check Differential Oil Level – Check the differential oil level per the component manufacturer's instructions.

Change Differential Oil – Drain and replace differential oil. Use oil meeting, at least, the minimum specifications of the component manufacturer.

Check Lift Cylinders for Leaks – Inspect cylinders for signs of leaking. Repair as necessary.

Torque Rear Axle Mounting Bolts – Re-torque rear axle mounting bolts.

CHASSIS

Check Front Axle Oil Level (If Applicable) – Check oil level in front axle hubcaps. Fill to proper level as necessary.

Repack Front Wheel Bearings (If Applicable) – Remove front hubs and repack the bearings using grease meeting, at least, the minimum specifications of the component manufacturer.

Check Battery Cables and Hold Downs – Inspect battery cables for cracks or signs of abrasion or breaking. Repair and reroute as needed. Insure that batteries are properly secured.

Check Batteries for Cracks or Acid Leaks – Inspect batteries for signs of damage. Replace as necessary.

Clean Battery Cable Connections – Remove cable terminals from batteries, clean connections, reattach cable terminals.

Check Battery Box Cover Hold Downs – Check bolts or rubber latches to insure that the battery box cover is secured.

Drain Water from Air Tanks – With air system charged, open each manual drains until all moisture is removed from system.

Check and Torque All Wheel Nuts – Inspect all wheel nuts for signs of wear or damage. Loosen outer nuts on dual wheels before tightening inner nuts. Re-torque all nuts to 450 – 500 ft/lbs.

Check Wheels – Inspect all wheels for signs of damage including oversized holes and cracks.

Check Tire Pressure, Tread Depth and Condition – Inspect tires for damage and wear. Adjust to the proper air pressure.

Check Rear Axle Planetary Fluid Level (If Applicable) – Check and adjust lubricant level in planetary housings per the component manufacturer's instructions.

Inspect Catwalk – Inspect catwalk for proper mounting and the absence of cracks and trip points.

TICO MANUFACTURING PREVENTATIVE MAINTENANCE GUIDELINES (CONTINUED)

CHASSIS (CONTINUED)

Check Frame for Cracks – Inspect frame rails and cross members for cracks and bending.

Check Mud Flaps / Fenders (If Applicable) – If equipped with mud flaps and/or fender, inspect these items for proper mounting and damage.

Change Hydraulic System Filter – Remove and replace the external hydraulic filter.

Check Hydraulic Fluid Level – Start engine, raise and lower the boom two to three times to insure that system components are filled. Lower boom to full down position, shut off engine and check fluid level. Fill as necessary.

Change Hydraulic Fluid – Drain hydraulic tank and refill with ATF-Dexron fluid.

Clean Hydraulic Tank Vent – Remove any dirt collecting around vent and insure that vent is clear.

LUBRICATION

Check / Lubricate Rear Door Bushings – Lubricate with lithium grease or light weight oil.

Check / Lubricate Steering Slip Joint – Inspect slip joint for wear or damage. Lubricate with lithium grease.

Check / Lubricate Steering U-Joints – Inspect u-joints for wear or damage. Lubricate with lithium grease.

Check / Lubricate King Pins and Tie Rod Ends – Inspect kingpins and tie rod ends for wear or damage. Lubricate with lithium grease.

Check / Lubricate Drag Link – Inspect drag link rod ends for wear or damage. Lubricate with lithium grease.

Check / Lubricate Slack Adjusters – Inspect brake slack adjusters for wear or damage. Measure the brake actuator stroke. If this measurement exceeds the component manufacturer's recommendation check brake lining and adjuster to determine which is the cause of the excessive stroke and repair as necessary.

Check / Lubricate Spring Pins and Bushings – Inspect spring pins, hangers and pin bushings for wear or damage. Lubricate with lithium grease.

Check / Lubricate Driveline U-Joints – Inspect driveline and u-joints for wear or damage. Lubricate with lithium grease.

Check / Lubricate Lower Boom Cylinder Bearings – Inspect lower boom cylinder bearings for wear or damage. Lubricate with lithium grease.

Add Grease to Autolube Reservoir – If the vehicle is equipped with an automatic lubrication system inspect all lubrication points for sufficient grease. Fill the system's reservoir with the proper type and quantity of grease per the component manufacturer's recommendation.

Clean, Check and Adjust 5th Wheel Jaws – Remove dirt and excessive grease from the 5th wheeljaws. Using a 5th wheel jaw gauge measure the free play. If free play exceeds 1/8" determine the cause of the excessive play and either repair or replace the jaws per the component manufacturer's recommendation.

Check / Lubricate 5th Wheel Top Plate – Clean and inspect the 5th wheel top plate for cracks or other damage. Apply lithium grease to the surface of the top plate.

Check / Lubricate 5th Wheel Pivot Pins – Inspect 5th wheel pivot pins for wear or damage. Lubricate with lithium grease.

Check / Lubricate Boom Pivot Bearings – Inspect boom pivot bearings for wear or damage. Lubricate with lithium grease.

Check / Lubricate Upper Boom Cylinder Bearing – Inspect upper boom cylinder bearings for wear or damage. Lubricate with lithium grease.

TICO MANUFACTURING PREVENTATIVE MAINTENANCE GUIDELINES (CONTINUED)

TEST DRIVE

Drive Vehicle to Check for Overall Operation – Start and drive vehicle. Test the operation of all systems and components.

ON-ROAD CERTIFIED ENGINES

DIESEL EXHAUST FLUID (DEF) – On-Road Certified Engines after December 31st, 2009 may require the use of Diesel Exhaust Fluid (DEF) stored in a tank on the left frame rail behind the Diesel Fuel Tank. A DEF gauge and dash warning lamp that indicates low DEF levels will be located on the upper left section of the dash gauge cluster. Refilling this tank with DEF is critical to your vehicle to comply with the EPA emission regulation. All On-Road Certified Engine equipped vehicles have the following warning lamps to aid in determining when to add DEF or to indicate a malfunction:

- **Diesel Exhaust Fluid (DEF) Lamp**

Illuminated – An illuminated DEF lamp is an indication that the DEF level is low. This can be corrected by refilling the DEF tank.

Flashing – A flashing DEF lamp indicates that the DEF level has fallen below a critical level. This can be corrected by refilling the DEF tank.

Flashing with Warning or Check Engine Light – A flashing DEF lamp combined with an illuminated Warning or Check Engine lamp indicated that the DEF level is critically low and you will experience a power loss. Normal engine power will be restored after refilling the DEF tank.

Stop Engine Lamp with Flashing DEF and Warning or Check Engine Lamp – If the engine has been shut down or has idled for 20 hours after the DEF tank has been run dry, the Stop Engine Lamp will also be illuminated along with the flashing DEF Lamp and illuminated Warning or Check Engine Lamp. Engine power will continue to be reduced automatically. The vehicle will also be limited to 5 miles (8 km) per hour (MPH) speed limit. Normal power and vehicle speed will be restored after refilling the DEF tank.



REGENERATION – On road engines may require, from time to time, a manual Regeneration to clean the Aftertreatment System. All on road engine equipped vehicles have the following warning lamps to aid in determining when a Manual Regeneration is necessary:

- **High Exhaust System Temperature (HEST) Lamp**

The HEST Lamp illuminates to indicate that high exhaust temperature may exist due to Aftertreatment Regeneration. This is normal and does not signify the need for any kind of vehicle or engine service. When the HEST Lamp is illuminated, ensure that the exhaust pipe outlet is not directed at any surface or material that will melt, burn, or explode. Reference your Cummins Owners Manual from complete instructions.

TICO MANUFACTURING PREVENTATIVE MAINTENANCE GUIDELINES (CONTINUED)

• **Aftertreatment Diesel Particulate Filter (DPF) Lamp**

The DPF Lamp indicates, when illuminated or flashing, that the Aftertreatment Diesel Particulate Filter requires Regeneration.

Illuminated DPF Lamp – When the DPF Lamp illuminates, Regeneration must be accomplished within the next 2–6 hours of operation. This is accomplished by:

- Changing to a more challenging duty cycle, such as highway driving, for at least 20 minutes.

OR

- Performing a “Parked” Regeneration.

Flashing DPF Lamp – When the DPF Lamp flashes, the actions stated above should be performed in the next 1–2 hours. In addition, engine power may be reduced automatically.

- A “Parked” Regeneration may be performed using the Manual Regeneration Switch on the Dash. This should only be performed if and when the above stated events have occurred.

Flashing DPF Lamp with a Check Engine Lamp – A flashing DPF Lamp with an illuminated Check Engine Lamp indicates that the Aftertreatment Diesel Particulate Filter needs Regeneration Immediately. Engine power will be reduced automatically. A “Parked” Regeneration is required.



WARNING — Aftertreatment Regeneration should only be performed with a parked vehicle. Place the transmission in neutral and apply the parking brake. During Regeneration engine speed will be increased. Exhaust components will have extreme temperatures.



CAUTION — If a “Parked” Regeneration is not performed, the red “STOP ENGINE” Lamp will illuminate. The vehicle should be stopped as soon as it can safely be done and remain shut down until it can be serviced by a Cummins Authorized Repair Location.

EMISSION MAINTENANCE – On road engines (Cummins ISB's) require additional maintenance be performed on vehicles, engines, subsystems or components critical to emissions. The adjustment, cleaning, repair or replacement of the items listed shall occur at or before 150,000 miles or 4,500 hours intervals for medium duty diesel engines.

Items listed are:

- (A) Fuel injectors
- (B) Turbocharger
- (C) Electronic engine control unit and its associated sensors and actuators.
- (D) Particulate traps or trap-oxidizer system (including related components).
- (E) Exhaust gas recirculation system (including related control valves and tubing).
- (F) Catalytic converter.
- (G) Any other add-on emissions-related component (i.e., a component whose sole or primary purpose is to reduce emissions or whose failure will significantly degrade emissions control and whose function is not integral to the design and performance of the engine.)

TICO MANUFACTURING PREVENTATIVE MAINTENANCE GUIDELINES (CONTINUED)

CHASSIS LUBRICATION DIAGRAM

* = Both Sides

**= Both Sides Front And Rear

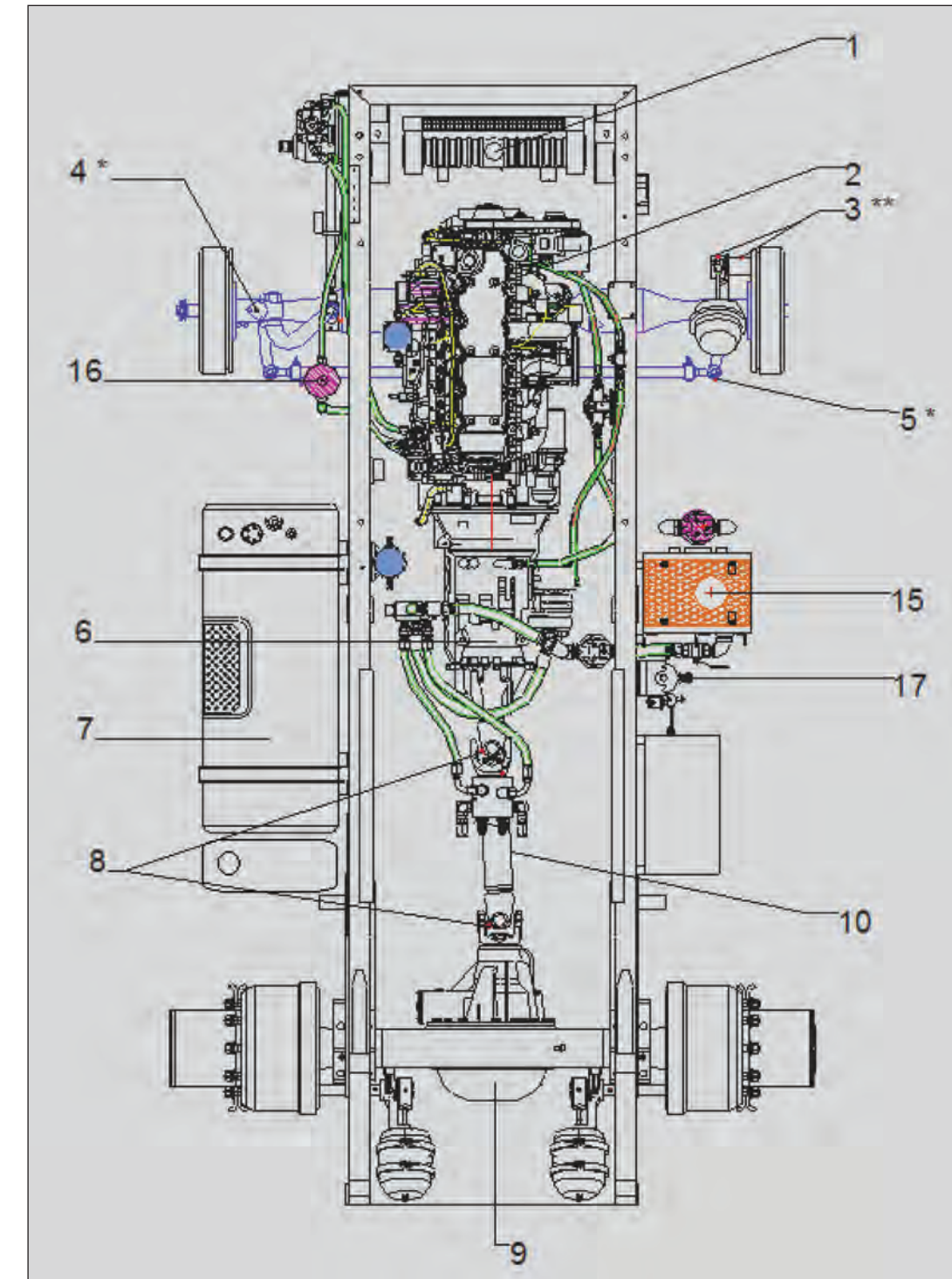

TICO MANUFACTURING PREVENTATIVE MAINTENANCE GUIDELINES (CONTINUED)

LUBRICATION CHART

KEY NO.	PART/DESCRIPTION	LUBRICANT USED/NOTES
1	Coolant/Antifreeze	50/50 Ethyl-Glycol / Water
2	Engine Oil	SAE 15W-40 (See Engine Operator Manual)
3	Slack Adjusters Brake Cam Pivot	Lithoplex RT #2
4	Front Axle King Pins	Lithoplex RT #2
5	Tie Rod Ends	Lithoplex RT #2
6	Transmission Fluid	Dexron III (Synthetic is optional) (See Transmission Operator Manual)
7	Diesel Fuel	No. 2 (See Engine Operator Manual)
8	Universal Joints	Lithoplex RT #2
9	Rear Axle Differential	85-140 (Synthetic is optional) (See Axle Operator Manual)
10	Drive Line Slip Yoke	Lithoplex RT #2
11	Spring Shackle Pins	Lithoplex RT #2
12	Front Wheel Bearings	85-140 (Synthetic is optional) (See Axle Operator Manual)
13	Drag Link Pivots	Lithoplex RT #2
14	Spring Guide Pin	Lithoplex RT #2
15	Hydraulic	Dexron III
16	Steering Fluid	Dexron III
17	Cab Lift Pump	Dexron III
18	Steering Shaft U-Joints	Lithoplex RT #2

TICO MANUFACTURING PREVENTATIVE MAINTENANCE GUIDELINES (CONTINUED)

BOOM AND FIFTH WHEEL LUBRICATION DIAGRAM

* = Both Sides

**= Both Sides Front And Rear

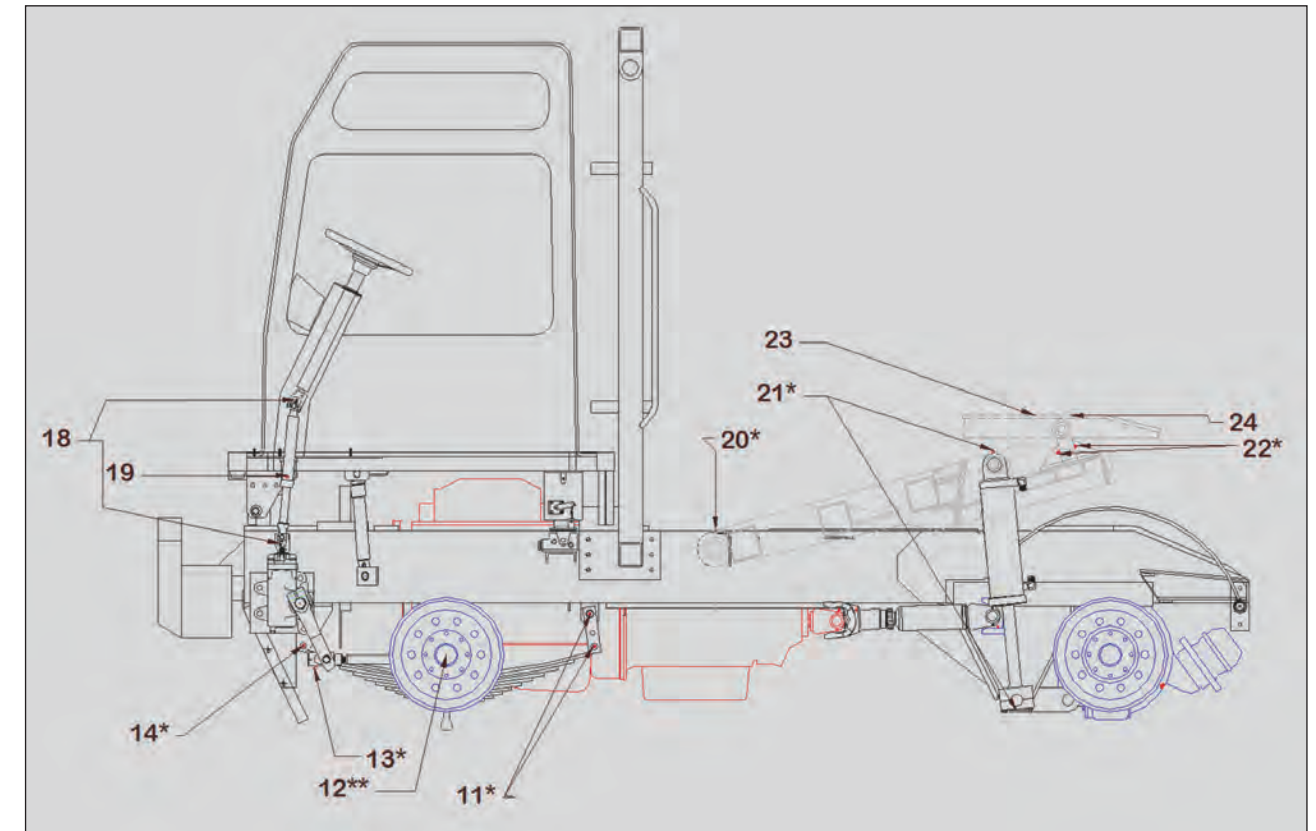

KEY NO.	PART/DESCRIPTION	LUBRICANT USED/NOTES
19	Steering Slip Joint	Lithoplex RT #2
20	Boom Pivot	Lithoplex RT #2
21	Cylinder Bearings	Lithoplex RT #2
22	Fifth Wheel Pivot	Lithoplex RT #2
23	Fifth Wheel Top Plate	Lithoplex RT #2
24	Fifth Wheel Jaws	Lithoplex RT #2



WARNING —

Battery posts, terminals and related accessories contain lead and lead compounds, chemicals known to the State of California to cause cancer and reproductive harm. Wash hands after handling.

CALIFORNIA PROPOSITION 65 WARNING —

Diesel engine exhaust and some of its constituents are known to the State of California to cause cancer, birth defects, and other reproductive harm.

Proposition 65, a California law, requires warnings on products which expose individuals in California to chemicals listed under that law, including certain chemicals in diesel engine exhaust.

